

University of  
**Waterloo**



# ***SCALING-UP A REACTIVE EXTRUSION OPERATION***

Estanislao Ortíz-Rodríguez

and

Costas Tzoganakis

# Outline

- Background
- Problem Description
- Results
- Conclusions
- Future Work

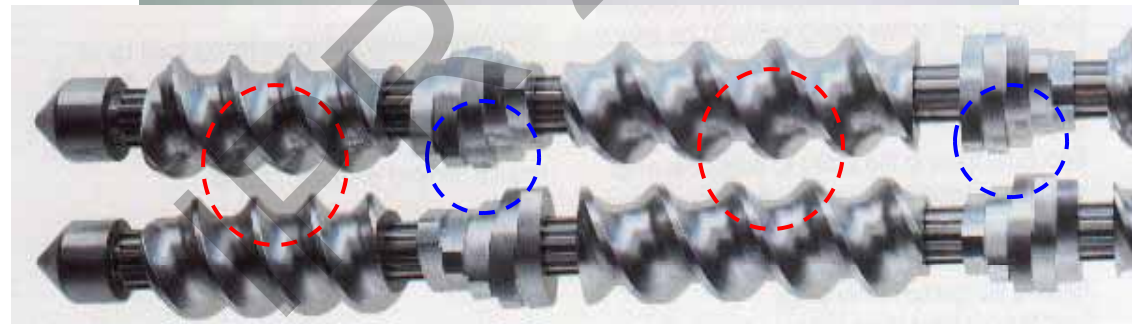
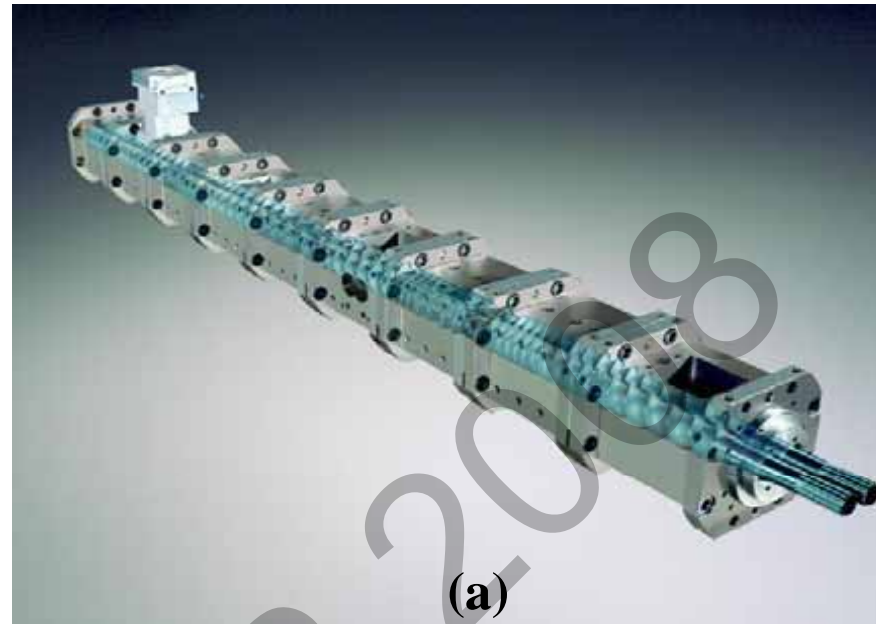

**Figure 1.** Modular configuration in a CSCO extruder (data Leistritz®).

## □ REX modeling.

- Conservation of mass, momentum and energy equations as well as the reaction kinetics equations need to be solved.
- One-dimensional (1D) and three-dimensional (3D) models can be used to simulate the system.
- 1D models: geometrical and flow simplifications are used. These models yield average values of processing parameters along the extruder, from hopper to die.
- 3D models are less simplified than 1D models. Conventionally, only fully filled sections of the extruder are simulated in 3D modeling.

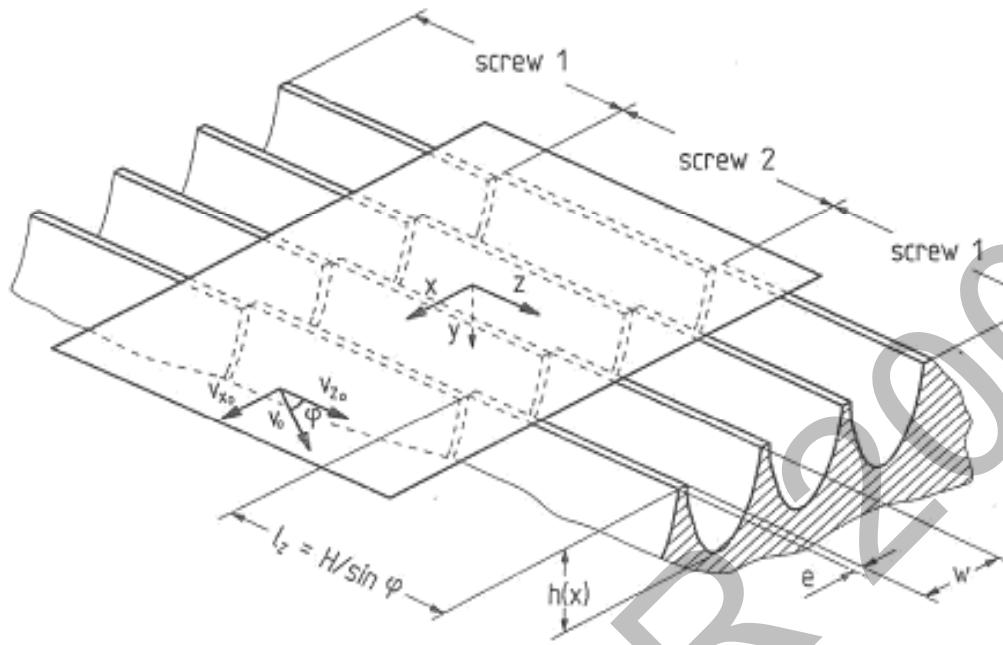

(a)

[After Michaeli et al., 1995]

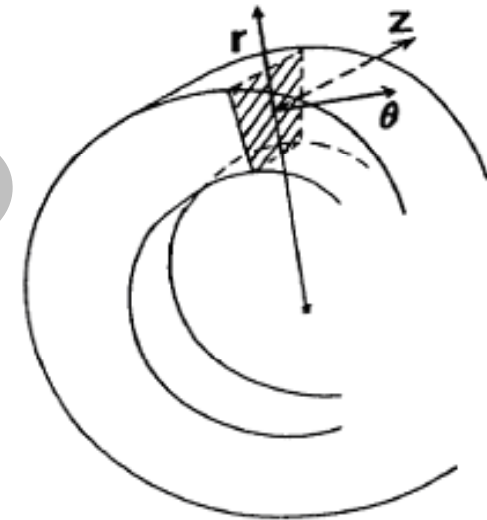

(b)

[After Vergnes et al., 1998]

**Figure 2.** Simplified flow geometries used in 1D modeling. a) Curved channels. b) “C-shaped” chambers.

- Scaling-up relations
  - Variables are scaled-up by a power of the diameter ratio (scale-up index).

$$D_2 = D_1 d^1$$

$$H_2 = H_1 d^h$$

$$L_2 = L_1 d^l$$

$$\phi_2 = \phi_1 d^\beta$$

$$N_2 = N_1 d^v$$

$$d = \frac{D_2}{D_1}$$

[1]

where

$D$ =Diameter,  $H$ =Max. channel depth

$L$ =Screw length,  $\phi$ =Helix angle,

$N$ =Screws rotating speed

- Equations 2.

-Conventional scale-up approach for non-reactive systems.

$$t \propto d^{l-1-v} \quad [2.a]$$

$$M \propto d^{2+h+v} \quad [2.b]$$

$$SEC \propto d^{n+n v-n h+l-h} \quad [2.c]$$

[Christiano, 1994; Rauwendaal, 1986, 1987]

2.a) Average residence time, 2.b) Mass throughput, 2.c) Specific Energy Consumption (SEC).

$n$ =Power-law index

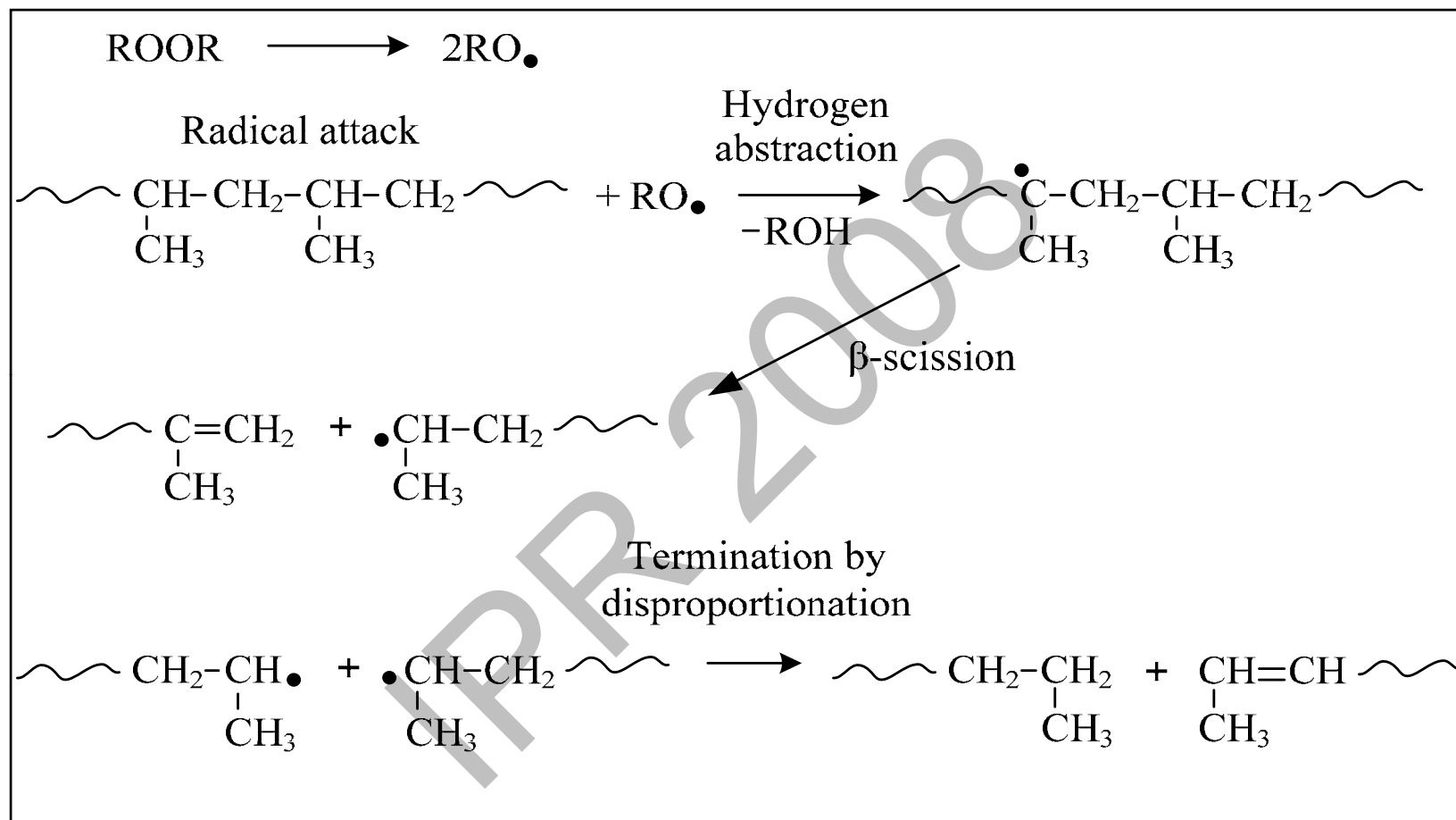

[After Xantos, 1992]

**Figure 3.** PP degradation (basic mechanisms).

### □ *Proposed scale-up approach.*

-To scale-up the REX operation from a reference extruder keeping a constant thermal time,  $t_T$ .

$$t_T = \int_0^t e^{-E/RT(t')} dt' \quad [3] \quad [\text{Nauman, 1977}]$$

$E$ =Activation energy of the reaction.  $T$  and  $t'$  temperature and residence time along a pathline.

-Simulation software (Strutt, 1998). Kinetics and rheokinetics parameters from Tzoganakis et al. (1988) and Wang (1996).

### □ *Additionally, comparison between scaling-up under constant $t_T$ and SEC.*

- The yielded Mws and PDIs, for scaling-up under the above procedures, are the evaluation parameters.

**Table 1.** Material data used for simulations.

<i>Parameter</i>	<i>Value</i>
Number-average molecular weight	51,800 g/mol
Weight-average molecular weight	279,700 g/mol
Melt density	750 kg/m <sup>3</sup>
Solid density	905 kg/m <sup>3</sup>
Bulk solid density	560 kg/m <sup>3</sup>
Pellet hydraulic diameter	2 mm
*Power law index	0.35
Consistency index	75480 Pa s <sup>n</sup>
Temperature factor ( $\beta$ )	0.0243(1/°C)
Melt thermal conductivity	0.185 W/(m °C)
Melt specific heat capacity	2.428 kJ/(kg °C)
Melting point	170 °C
Heat of fusion	133.850 kJ/kg

\* This value is used for all of the calculations to evaluate the scale-up index  $\nu$  from the equation of constant SEC.

**Table 2.** Summary of geometrical parameters of the extruders (data Leistritz®).

Extruder model	Barrel diameter (mm)	Channel depth (mm)	$d$	$h$	$\nu$
*LSM-30.34	34.00	3.99	---	---	---
ZSE-50	50.00	7.21	1.47	1.52	2.02
ZSE-67	67.00	8.05	1.98	1.03	0.11
ZSE-96	96.00	12.10	2.84	1.06	0.25

\*Indicates the reference extruder.

It can be noticed from the values of  $h$  and  $\nu$  that the ZSE-67 and ZSE-96 extruders are close geometrically scaled-up versions of the reference device.

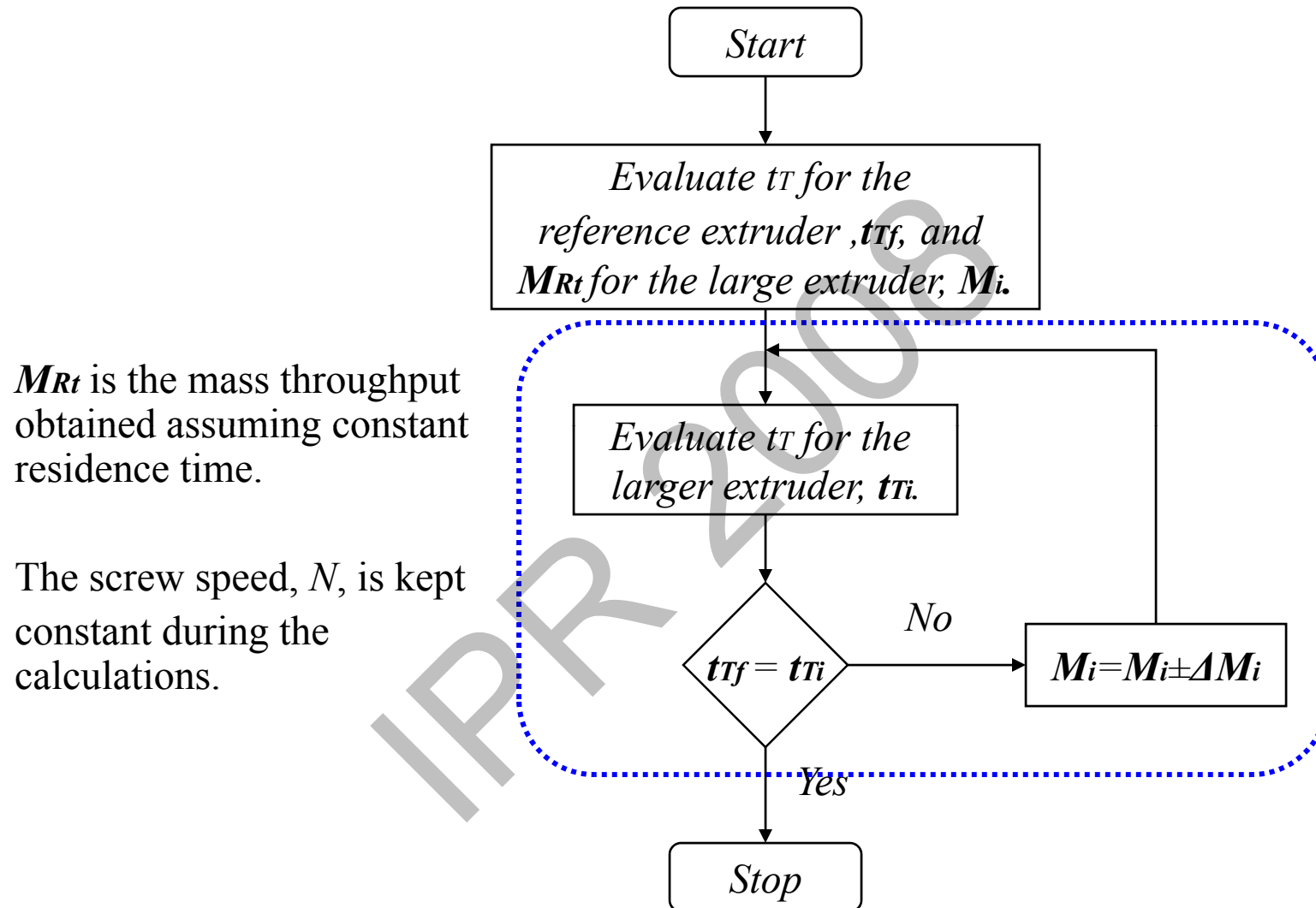

**Figure 4.** Implemented scale-up procedure for constant  $t_T$ .

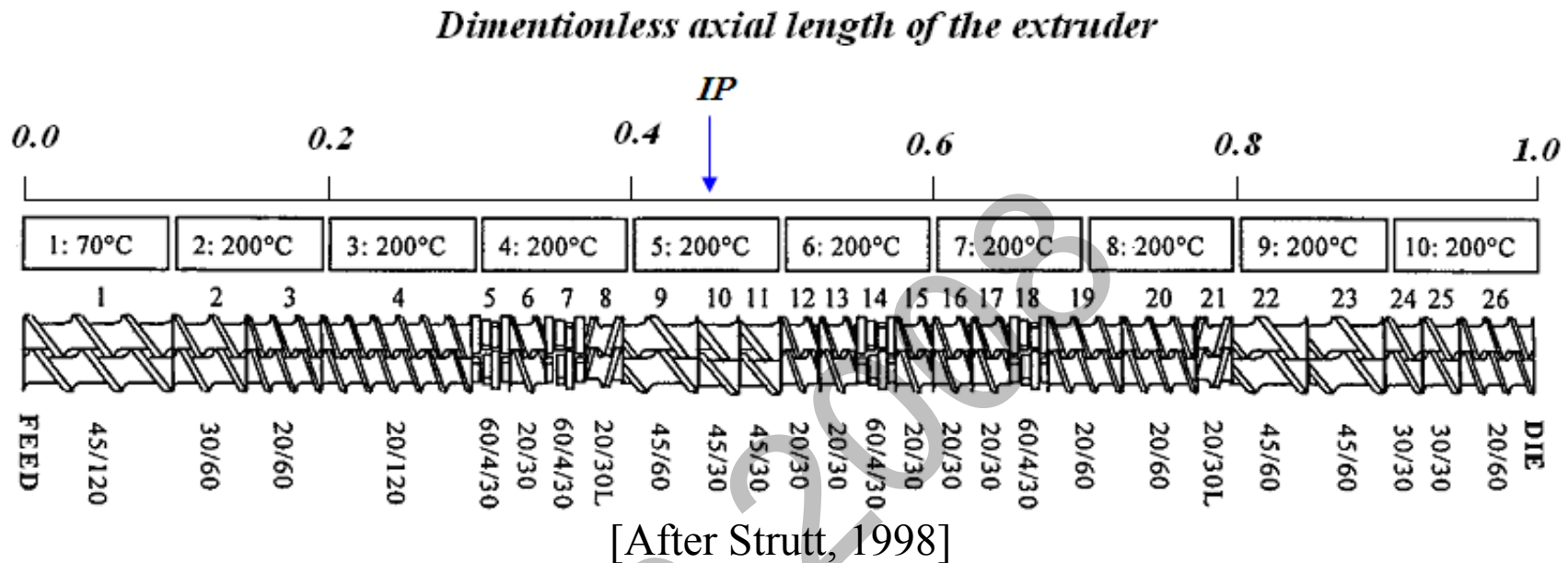

**Figure 5.** Extruder screw configuration for the LSM-30.34 extruder.

The peroxide injection port, *IP*, is located at a dimensionless axial distance equal to 0.45.

For the larger extruders, the length of the screw elements and kneading blocks is scaled-up proportionally to  $d^l$ .

**Table 3.** Initially simulated processing conditions.

Extruder model	Mass Throughput (kg/hr)	Screw speed (rpm)	Peroxide concentration (wt %)
LSM-30.34	5.0	100, 150, 200	0.01, 0.02, 0.10
ZSE-50	19.65	100, 150, 200	0.01, 0.02, 0.10
ZSE-67	39.52	100, 150, 200	0.01, 0.02, 0.10
ZSE-96	122.02	100, 150, 200	0.01, 0.02, 0.10

The mass throughput for the larger extruders corresponds to the scaled-up value of this parameter from the equation of constant residence time.

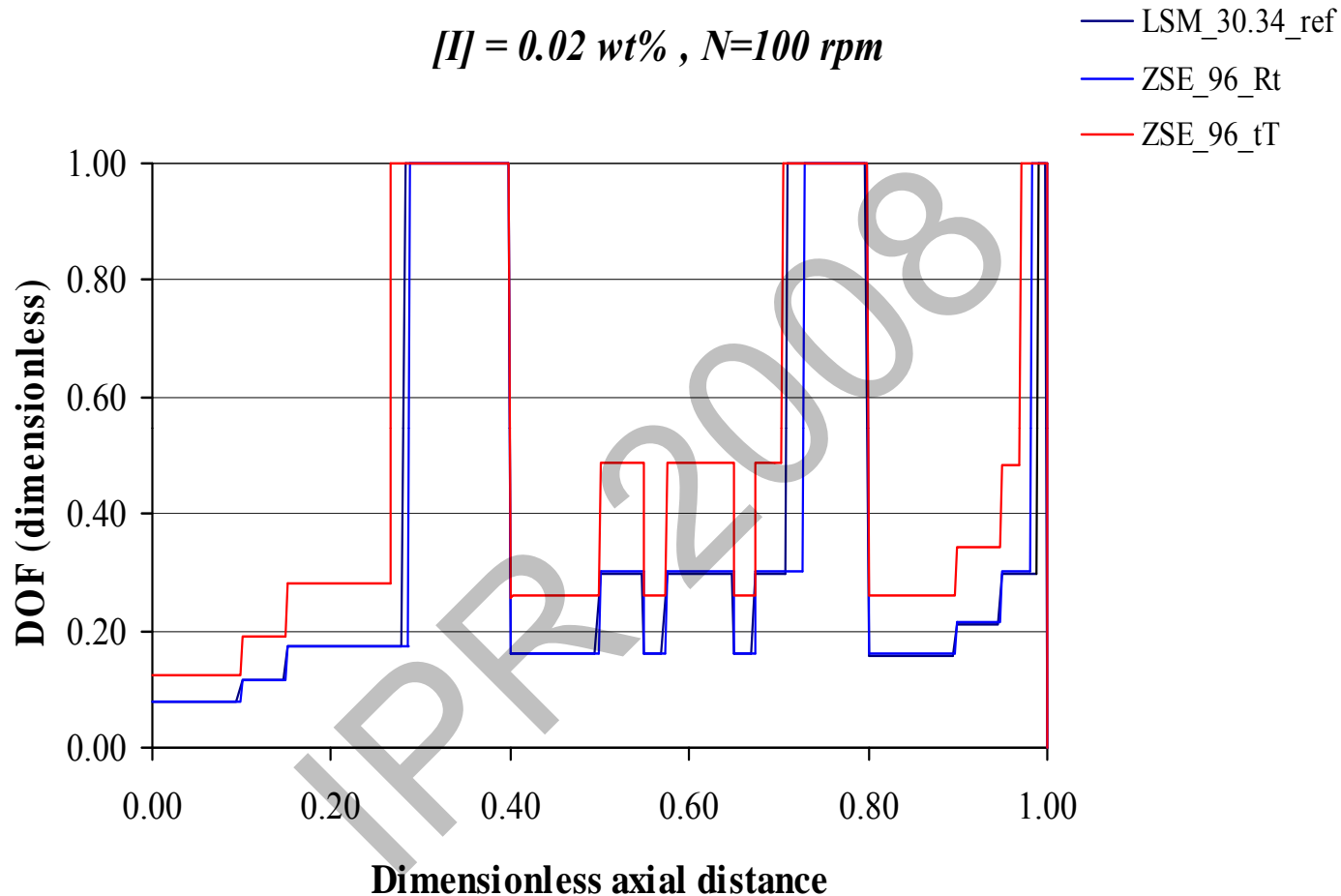

**Figure 6.** Degree-of-filling at the center of the screw channel (DOF).

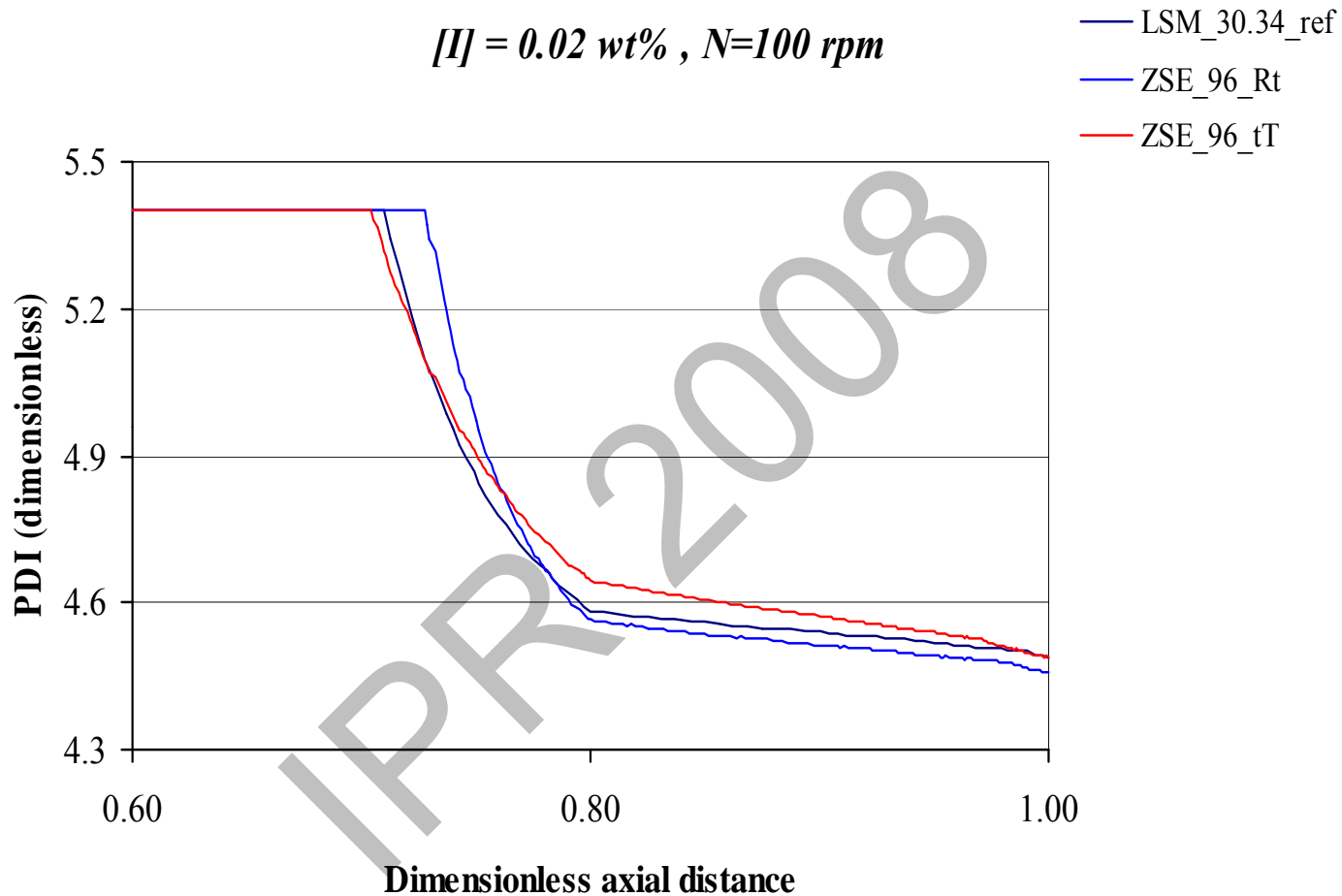

**Figure 7.** PDI variation along the axial distance of the extruder.

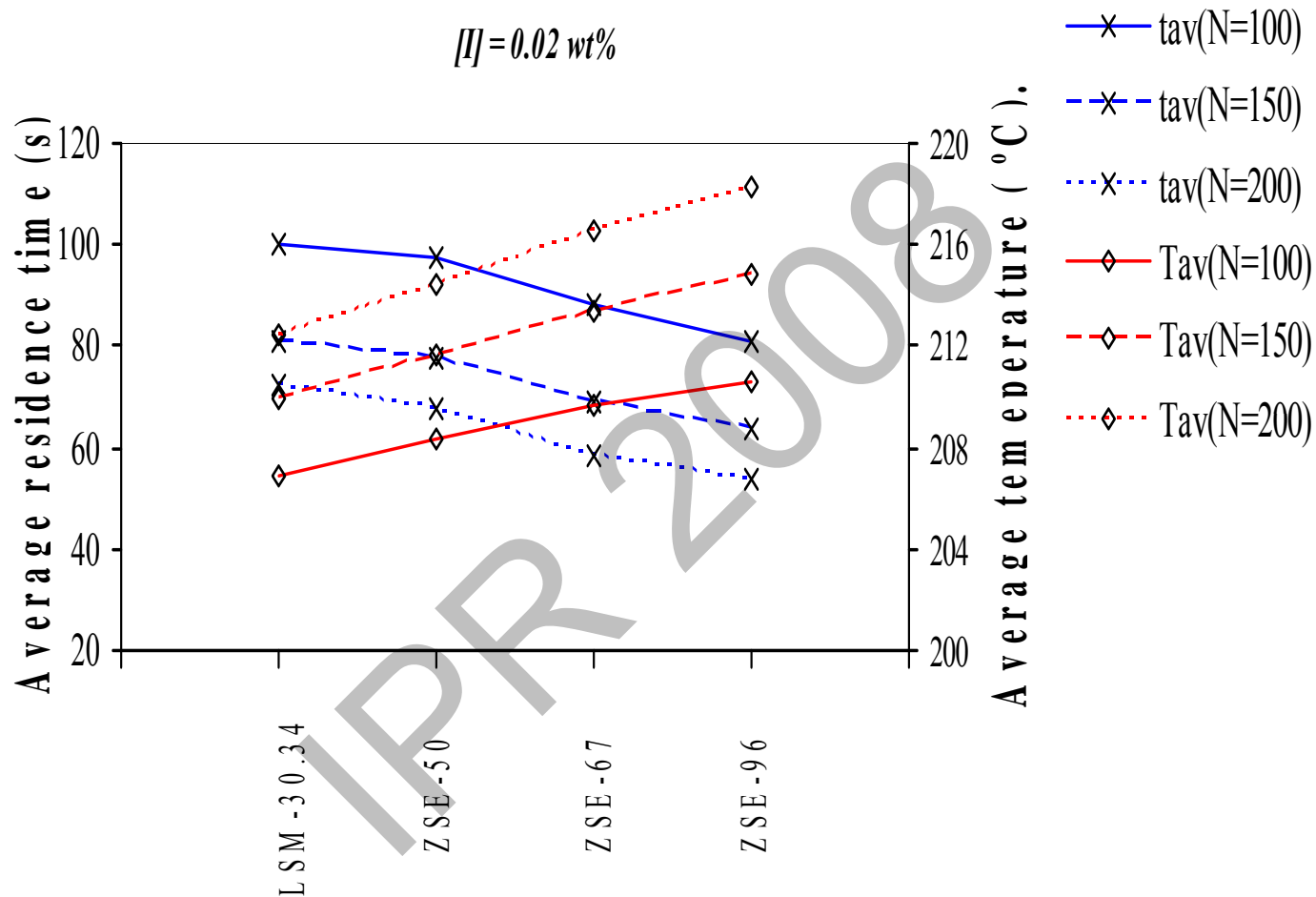

**Figure 8.** Temperature of reaction and residence time variations for the constant thermal time scale-up approach.

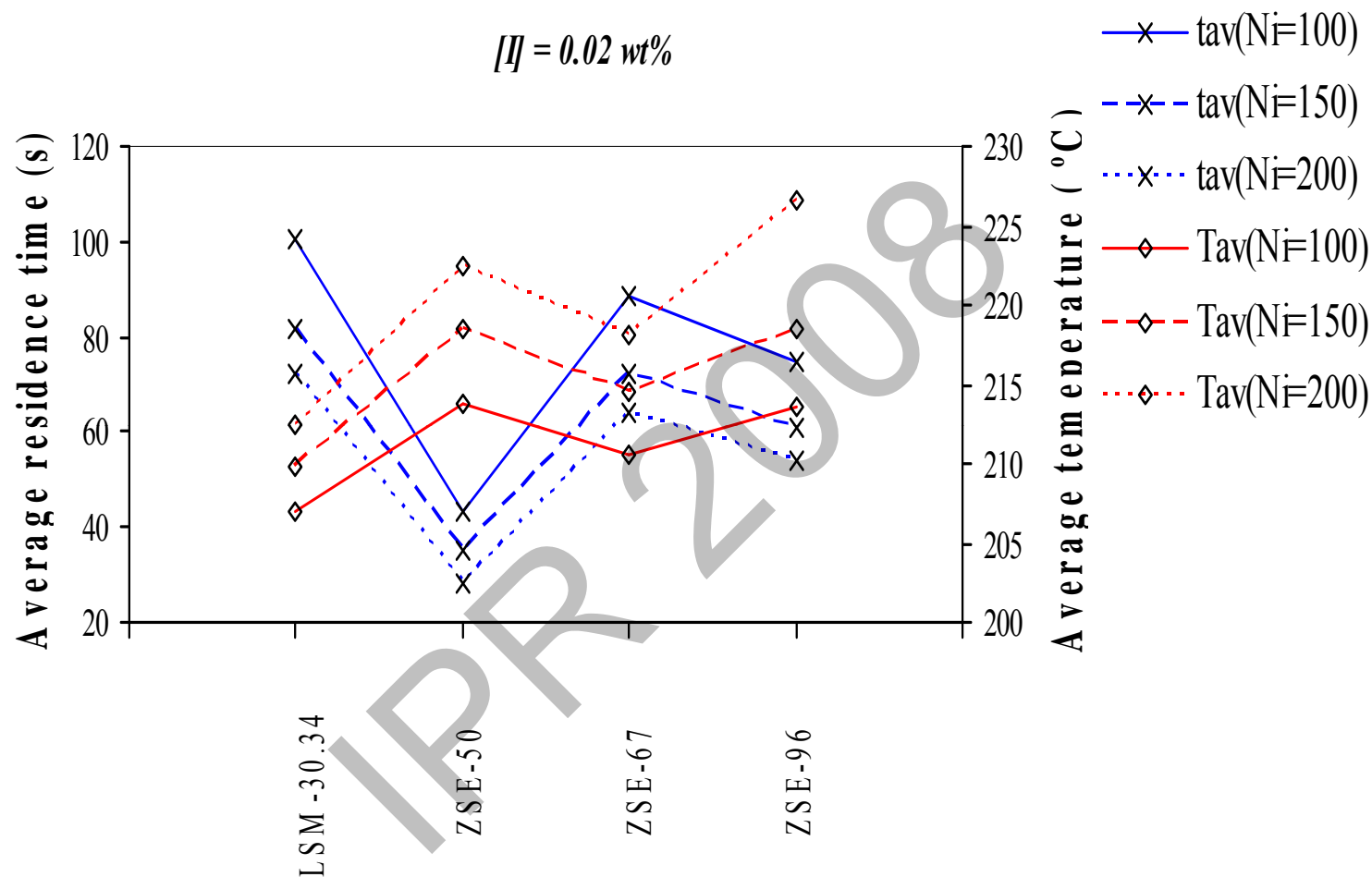

**Figure 9.** Temperature of reaction and residence time variations for the constant SEC scale-up approach.

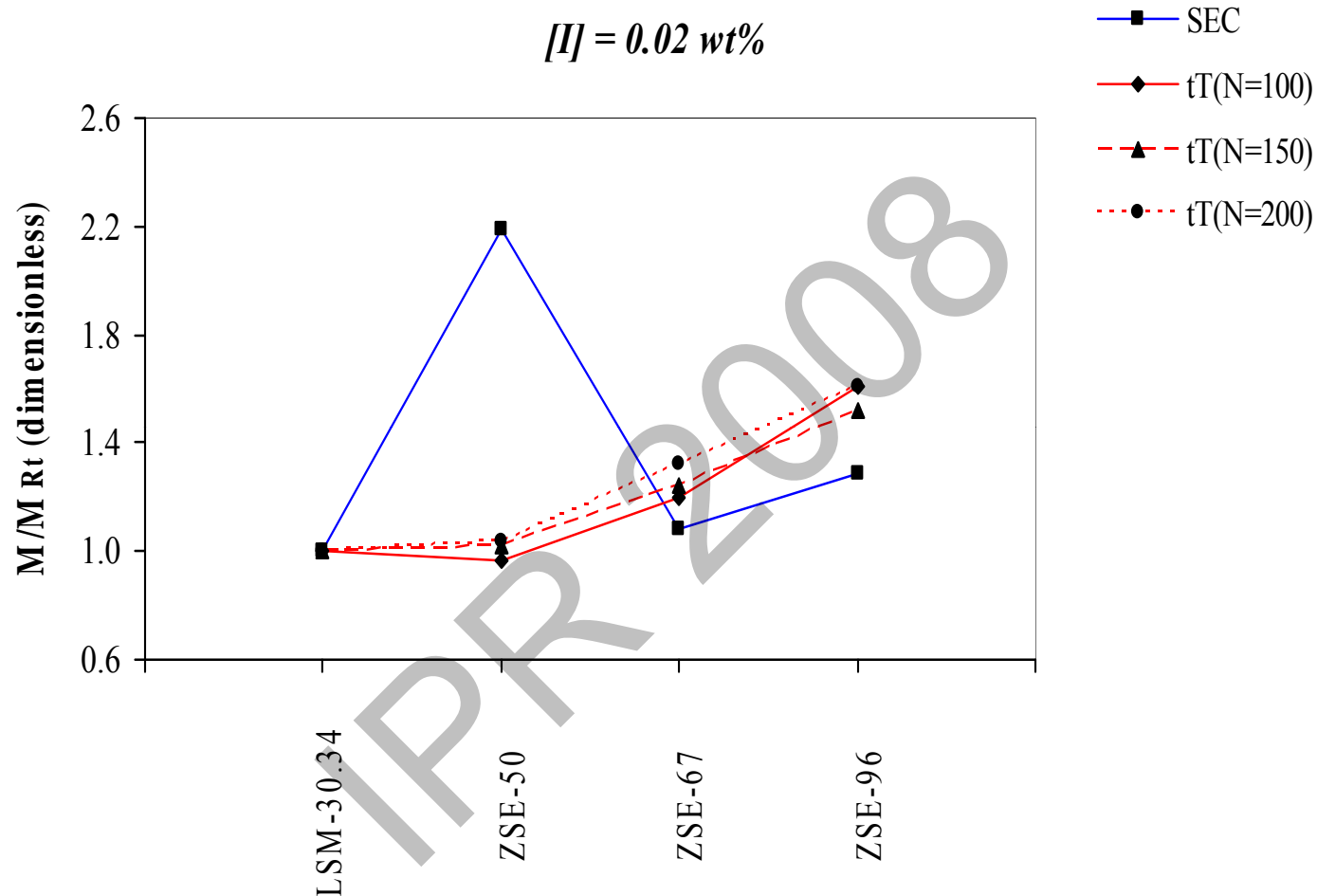

**Figure 10.** Scaled-up mass throughput variations for both  $t_T$  and SEC.

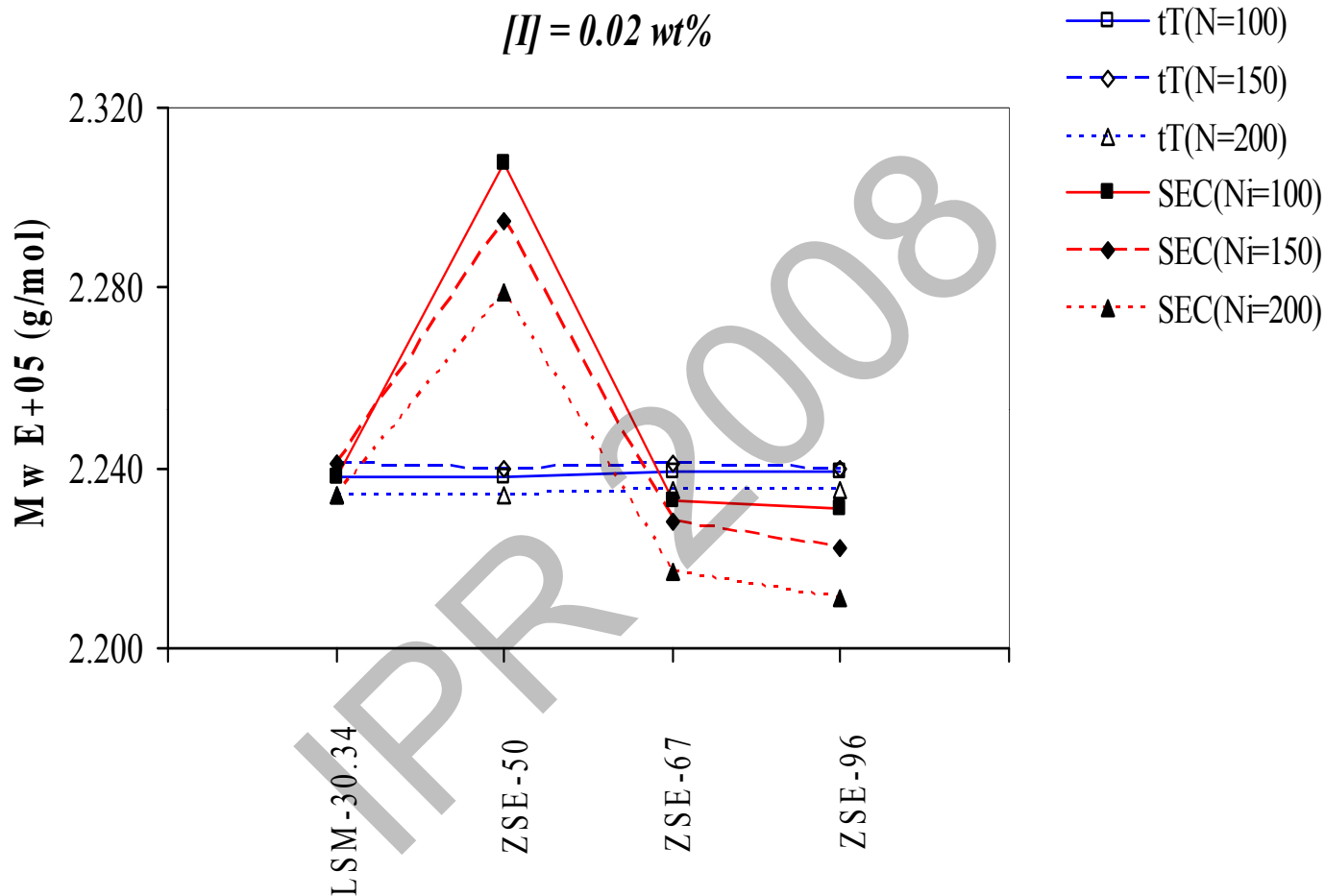
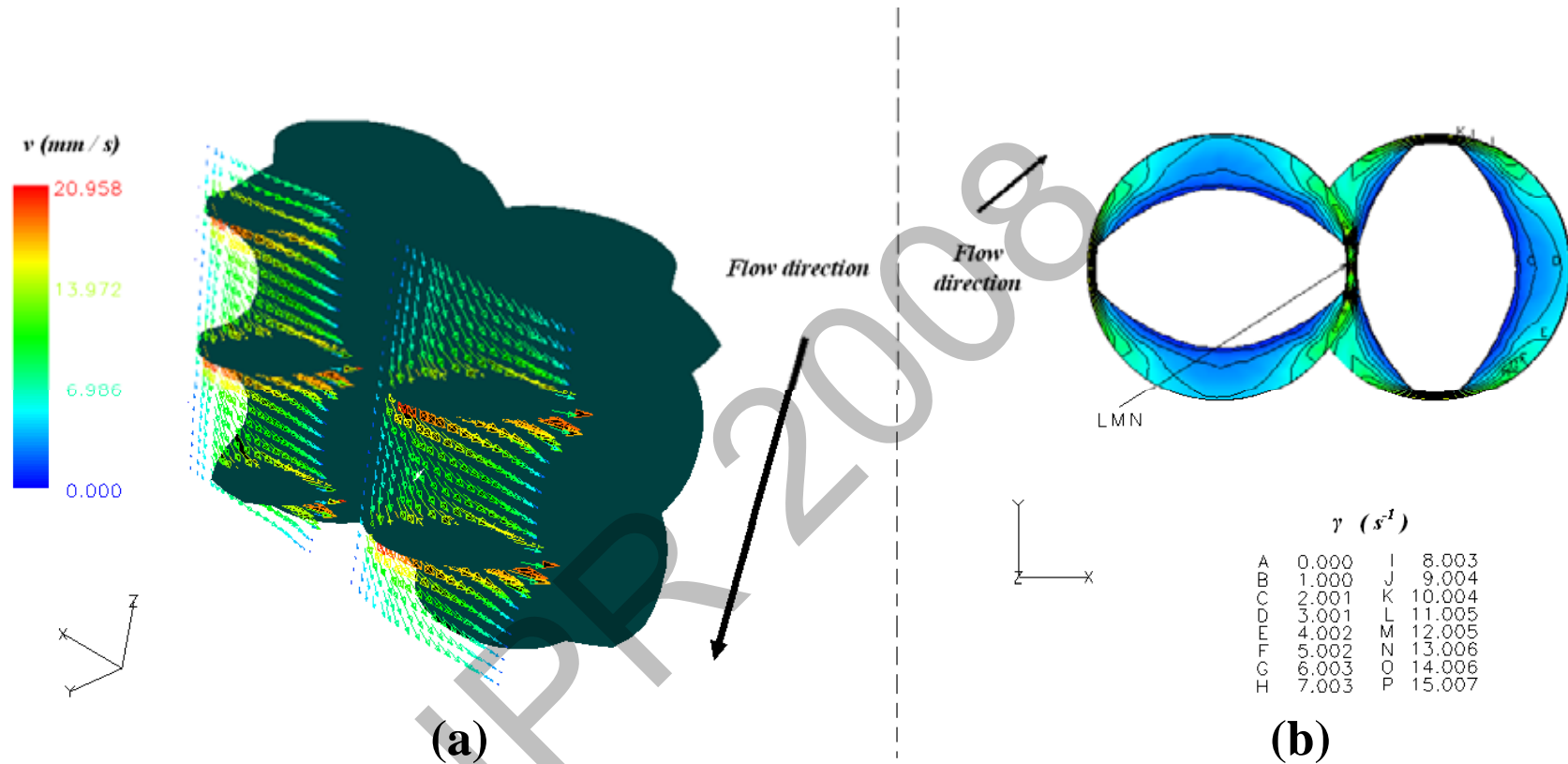

**Figure 11.** Mw and PDI variations for both  $t_T$  and SEC.

- Under the constant thermal time scale-up approach:
  - Good agreement between the PDIs and Mws of the reference and scale-up extruders are obtained.
  - When the residence time decreases, the temperature of reaction increases.
  - No significant variations of PDI and Mw as a function of the screw speed are observed.
- Overall, the constant thermal time scale-up procedure is a better way to scale-up the REX system than the constant SEC approach.

□ 3D simulations:

- To perform simulations for specific conditions selected from 1D simulations in order to get additional insight of the REX operation.
- To perform a mixing and residence time distribution (RTD) analysis.
- To calculate the average thermal time distribution, Mw, and PDI and compare these results to those of the 1D analysis.



**Figure 12.** Sample 3D results. (a) Velocity field for a cut  $y$ -plane  
(b) Shear rate contour plot for a cut  $z$ -plane.

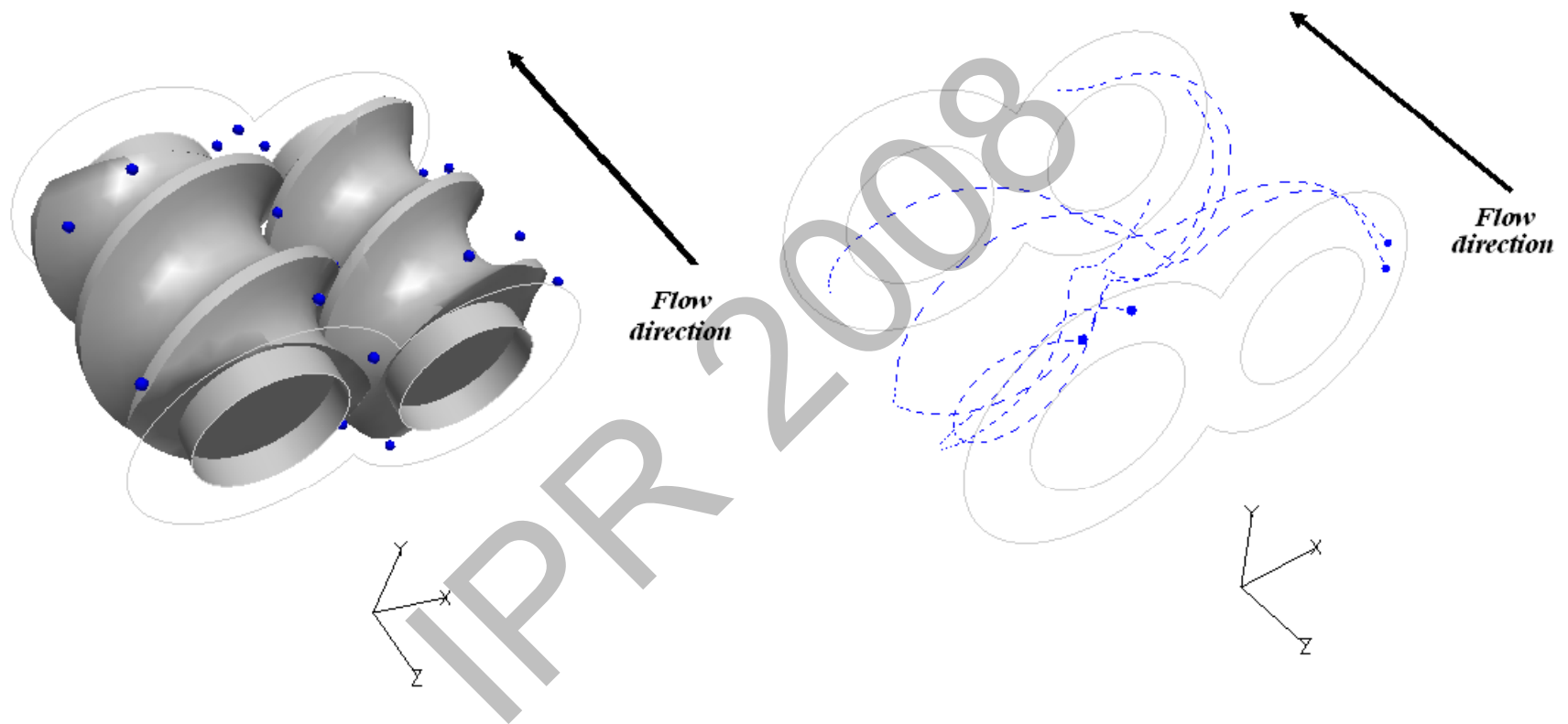

**Figure 13.** Sample 3D results. Particle tracking analysis.

## *Acknowledgements*

The financial support from the Mexican National Council for Science and Technology (CONACYT) is gratefully appreciated.

THANK YOU FOR YOUR  
ATTENTION

QUESTIONS/ANSWERS  
TIME

## Scale-up calculations for reactive extrusion operations

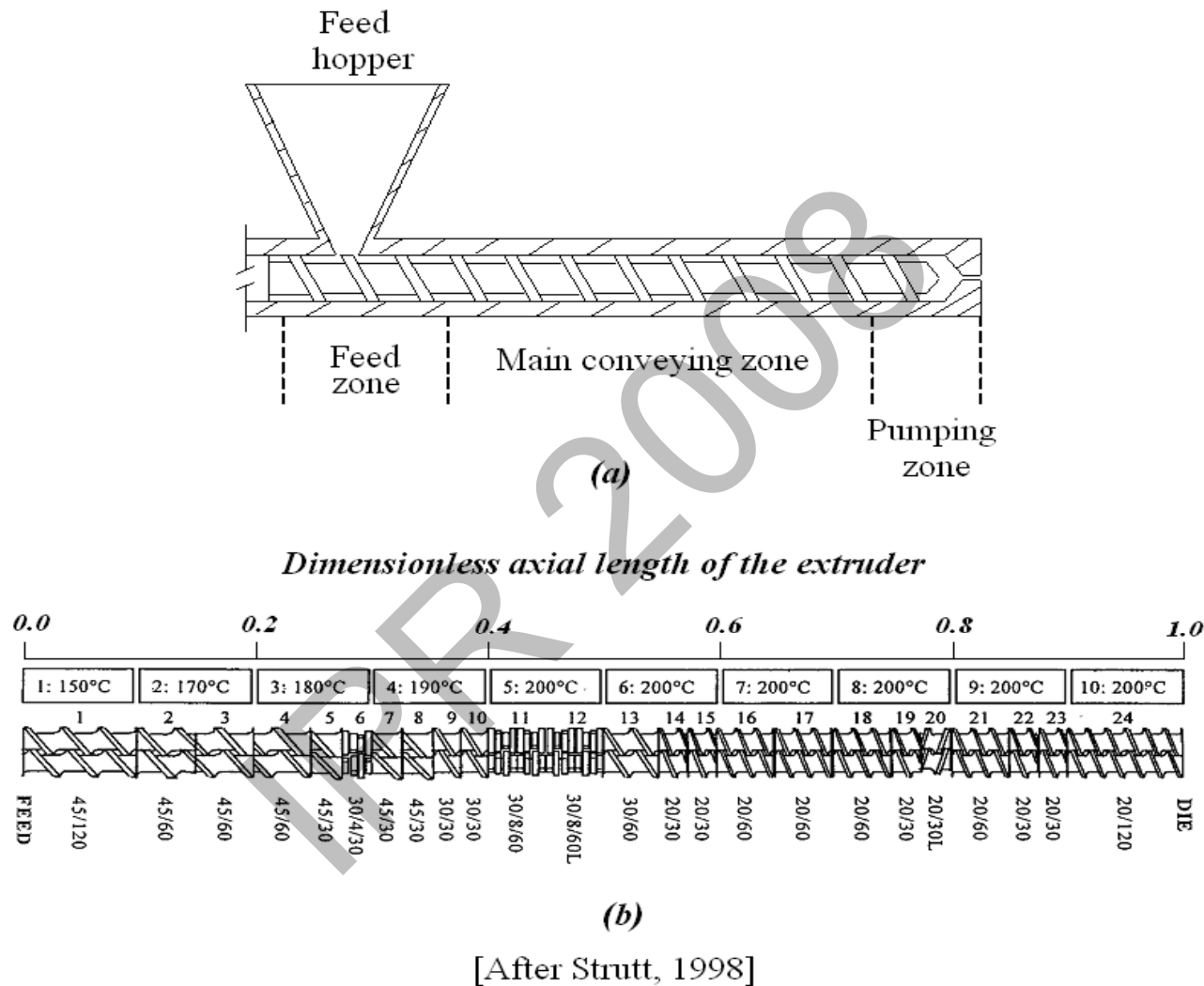

**Figure A.1.** General description of an extrusion operation.

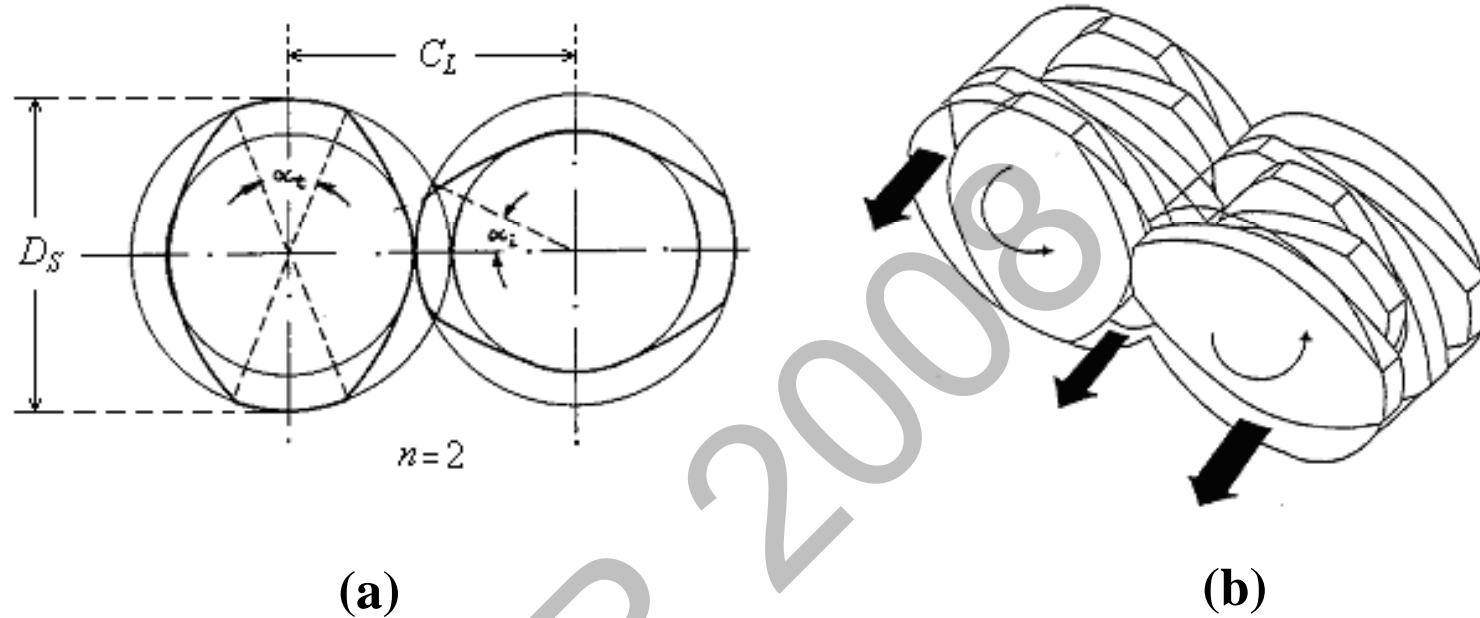

[After Booy, 1978]

[After Yang and Manas-Zloczower, 1992]

**Figure A.2.** a) Additional geometrical considerations for a twin screw extruder system. b) Kneading block geometry

$$\alpha_i = \frac{\pi}{2n} - \frac{\alpha_t}{2} \quad [\text{A.1}]$$

$$C_L = D_S \cos(\alpha_i) \quad [\text{A.2}]$$

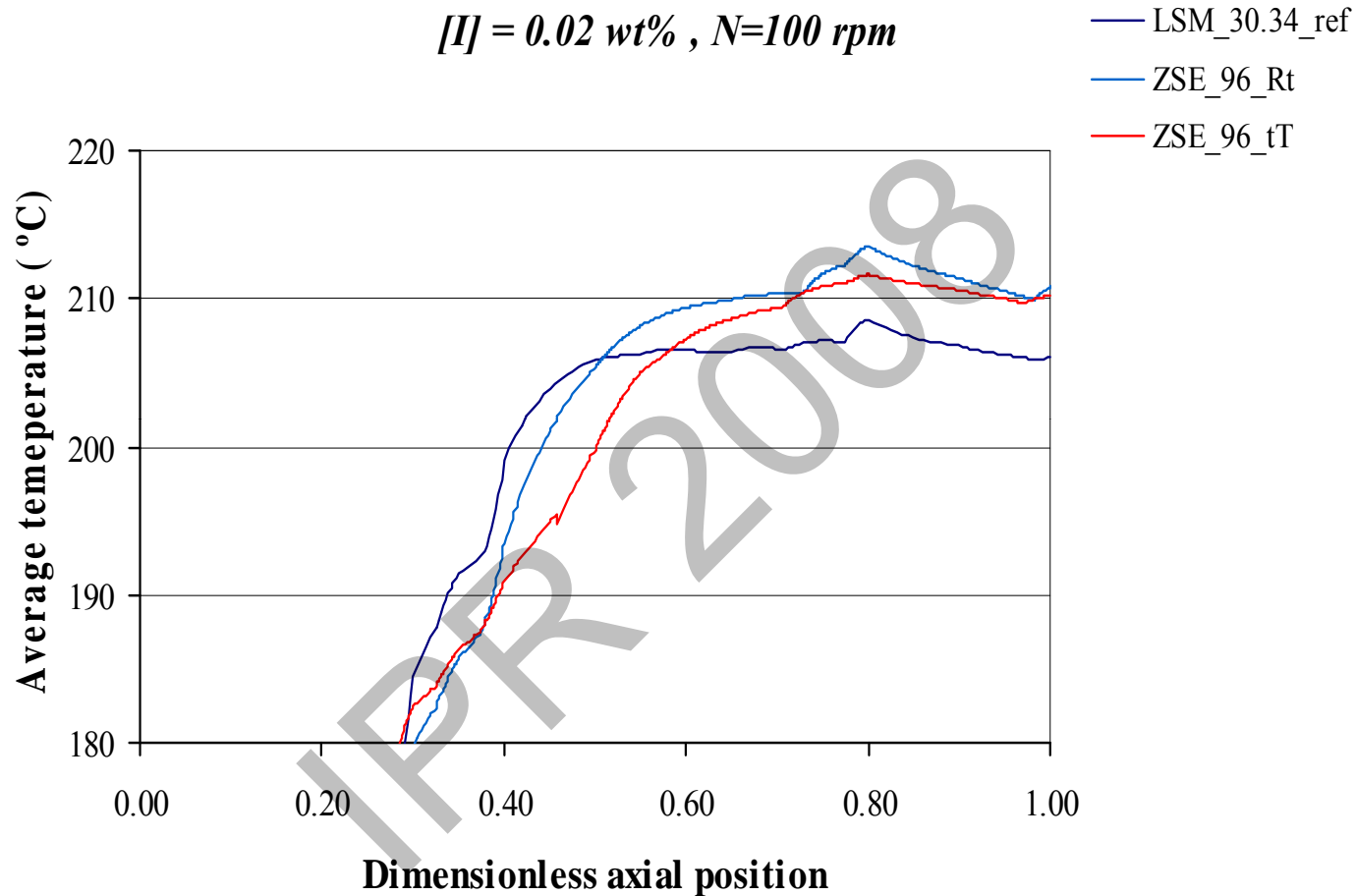

**Figure A.3.** Temperature variation along the axial distance of the extruder.

- Reaction kinetics for the peroxide-initiated degradation of PP (Tzoganakis et al. 1988). Initiation, chain scission, transfer, thermal degradation, termination by disproportionation are the steps considered by the model.

$$\begin{aligned} \frac{dI}{dt} &= -k_D I \\ \frac{dQ_0}{dt} &= 2f_p k_D I \frac{Q_1 - 3Q_0}{Q_1 - Q_0} \end{aligned} \quad \begin{aligned} Q_3 &= \frac{2Q_2}{Q_1 Q_0} (2Q_2 Q_0 - Q_1^2) \end{aligned} \quad \text{[A.4]}$$

$$\begin{aligned} \frac{dQ_1}{dt} &= -2f_p k_D I \frac{2Q_0}{Q_1 - Q_0} \\ \frac{dQ_2}{dt} &= 2f_p k_D I \frac{-(Q_3/3) + (Q_1/3) - 2Q_0}{Q_1 - Q_0} \end{aligned} \quad \begin{aligned} \bar{M}_n &= m_0 (Q_1 / Q_0) \\ \bar{M}_w &= m_0 (Q_2 / Q_1) \\ \bar{M}_z &= m_0 (Q_3 / Q_2) \end{aligned} \quad \text{[A.5]}$$

- $I$  is the peroxide concentration;  $f_p$  and  $k_d$ , are the peroxide decomposition efficiency and rate constant of decomposition, respectively.  $t$  is the time; and  $Q_i$  is the  $i$ th moment of the molecular weight distribution.  $M_n$ ,  $M_w$  and  $M_z$  are the number-, weight- and z- average molecular weights, respectively; and  $m_0$  is the monomer molecular weight.

- $M_w$  is a time dependent function; it depends on the evolution of the reaction (eq 15).

$$\bar{M}_w = m_0(Q_2 / Q_1) \quad [\text{A.6}]$$

$$\eta = \begin{cases} \frac{K}{\dot{\gamma}_0^{1-n}}, & \dot{\gamma} < \dot{\gamma}_0 \\ \frac{K}{\dot{\gamma}^{1-n}}, & \dot{\gamma} > \dot{\gamma}_0 \end{cases} \quad [\text{A.7}]$$

$$K = K(\bar{M}_w, T) \quad [\text{A.8}]$$

$$n = n(\bar{M}_w, T) \quad [\text{A.9}]$$

- Equations A.6-A.9 needs to be declared in POLYFLOW® as “user defined functions”.
- The *ith* moment of the molecular weight distribution are calculated from relations proposed by Tzoganakis et al. (1988).
- The power-law consistency index,  $K$ , and the power-law index,  $n$ , are expressed as polynomial functions (Strutt, 1998).

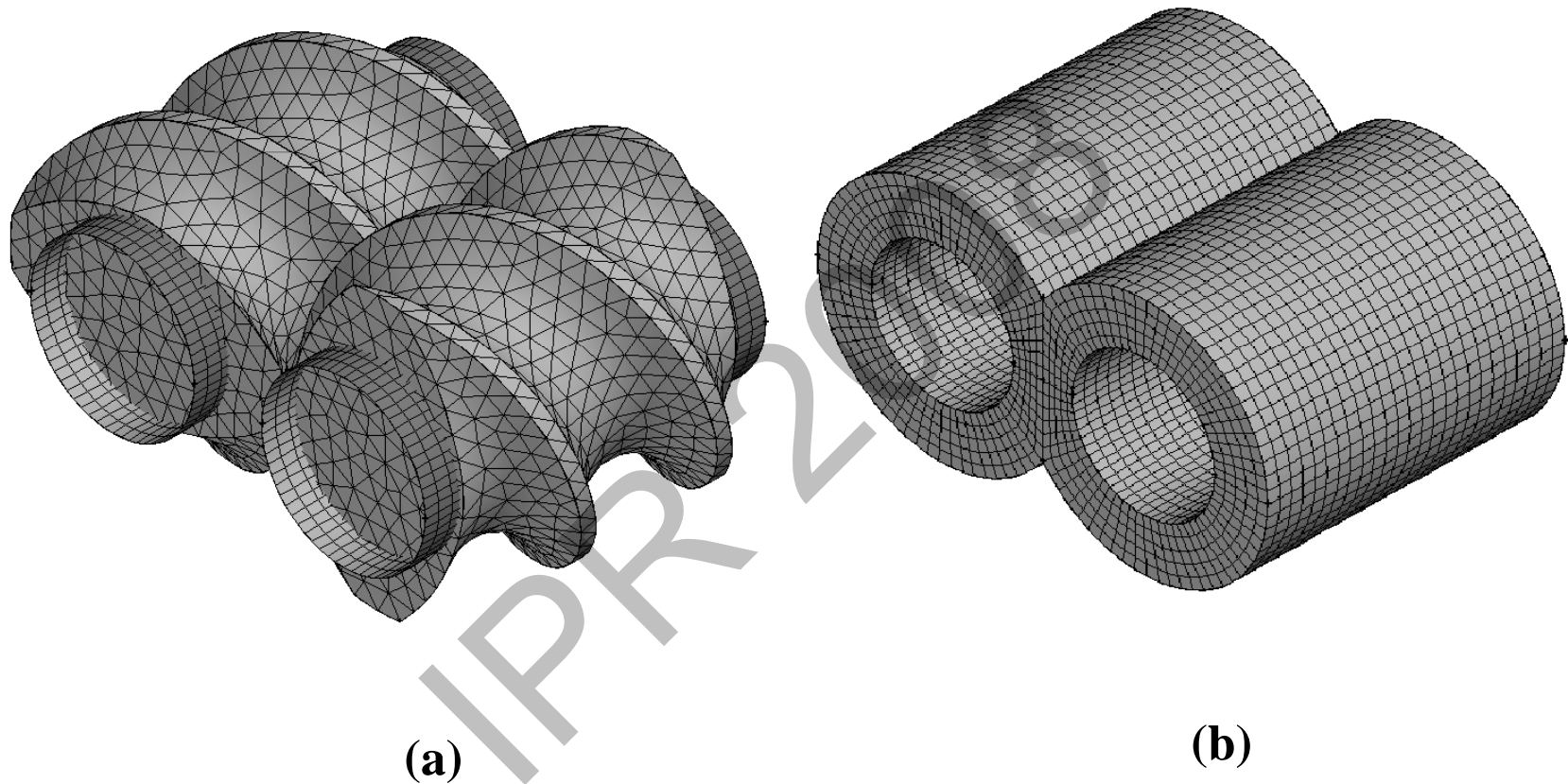

**Figure A.4.** (a) Screws and (b) flow-field meshed computational subdomains.

- 3D simulations.
  - Simulation of the flow in conveying screw elements of a CSCO extruder.
  - POLYFLOW®, a FEM software, is used; it applies the “mesh superposition technique” (Avalosse and Rubin, 2000). This technique is especially useful in describing the time dependency of the flow, which is due to the rotation of the screws.
  - Assumptions: Pseudo-steady state (steady state for a fixed position of the screws). Newtonian and isothermal flow.
  - Boundary conditions: Screw rotating speed=10 rpm. Gravity and inertia forces neglected. Non-slip conditions on solid boundaries.
  - Model: Generalized Newtonian fluid. Viscosity=5.0E04 Pa·s

**Table A.1** Peroxide half-lives in melt (sample results).

Ni=150 rpm. [I]=0.02 wt%

Extruder model	Constant $t_T$	Constant SEC
LSM-30.34	3.25	---
ZSE-50	3.33	2.23
ZSE-67	3.80	3.68
ZSE-96	4.33	3.92

For the higher values of the average temperature of reaction, the lower values of this parameter are observed (in agreement with results of Fig. 8).

**Table A.2** Peroxide half-live time as a function of the temperature of reaction.

Temperature (°C)	[I] <sub>1/2</sub> (s)
180	74.00
190	36.30
200	18.35
210	9.54
220	5.10