

Outline

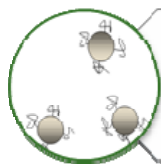

Background



Hydrogenation Reactions

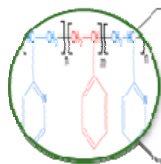

Polymers Synthesis

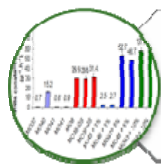

Results

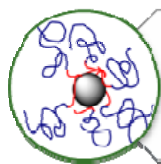

Conclusions

Overview

- Utilization of metallic **nanoparticles** as high performance catalysts
- Performance maximized by preventing aggregation with **polymeric** stabilizers

Nanoparticles

- Nanoparticles (10^{-9} m) \rightarrow New properties \rightarrow New applications
- Size effect: High surface-to-volume ratio

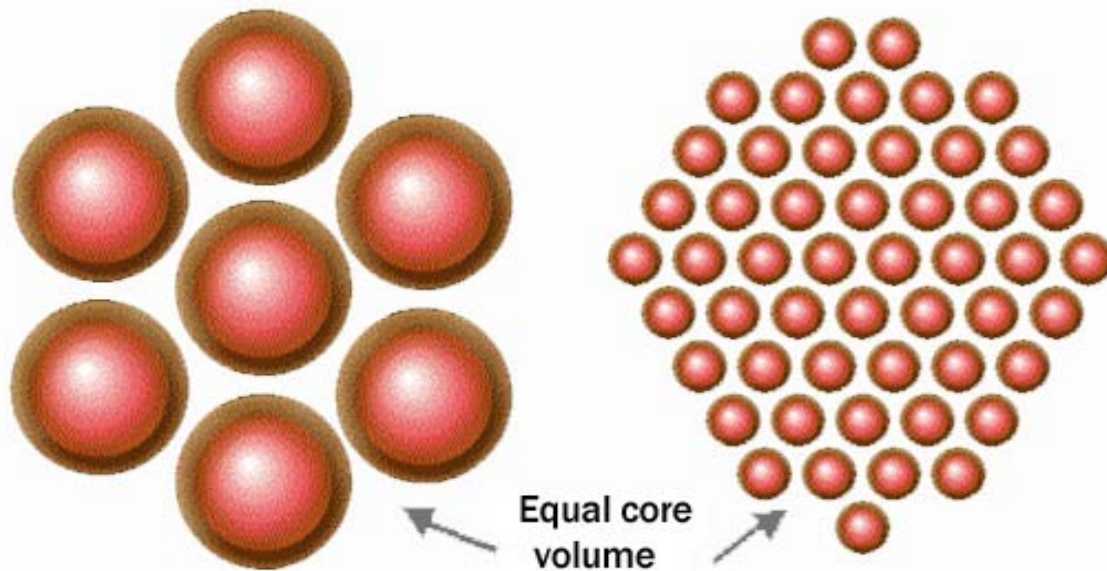

Catalysis

- Increased surface area → Increased density of reactive sites (kinks, edges: low coordination sites)
- Increased activity, selectivity

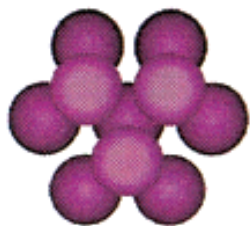

Total atoms: 10
Surface atoms: 10
Percent surface: 100%

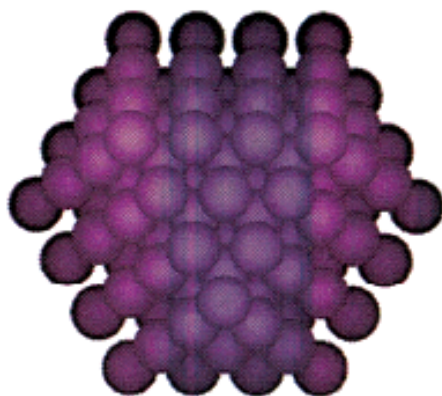

Total atoms: 92
Surface atoms: 74
Percent surface: 80%

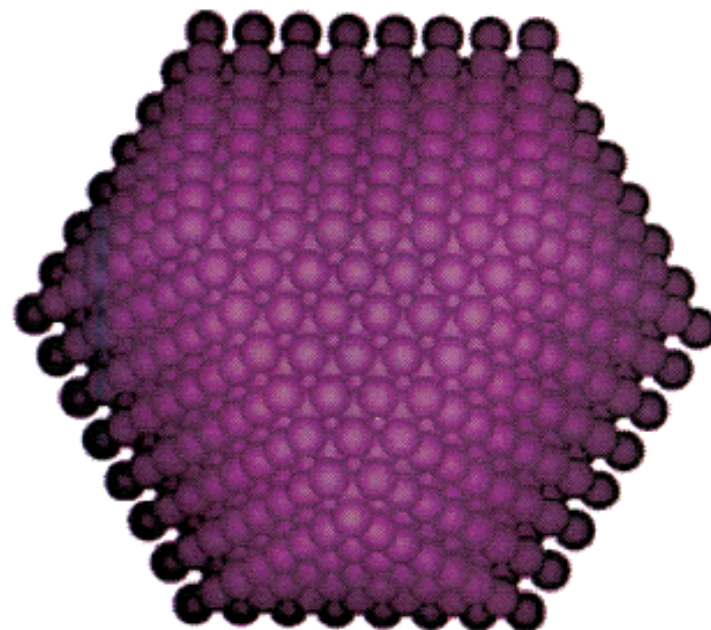

Total atoms: 792
Surface atoms: 394
Percent surface: 50%

van der Waals Interactions

■ Attractive interactions

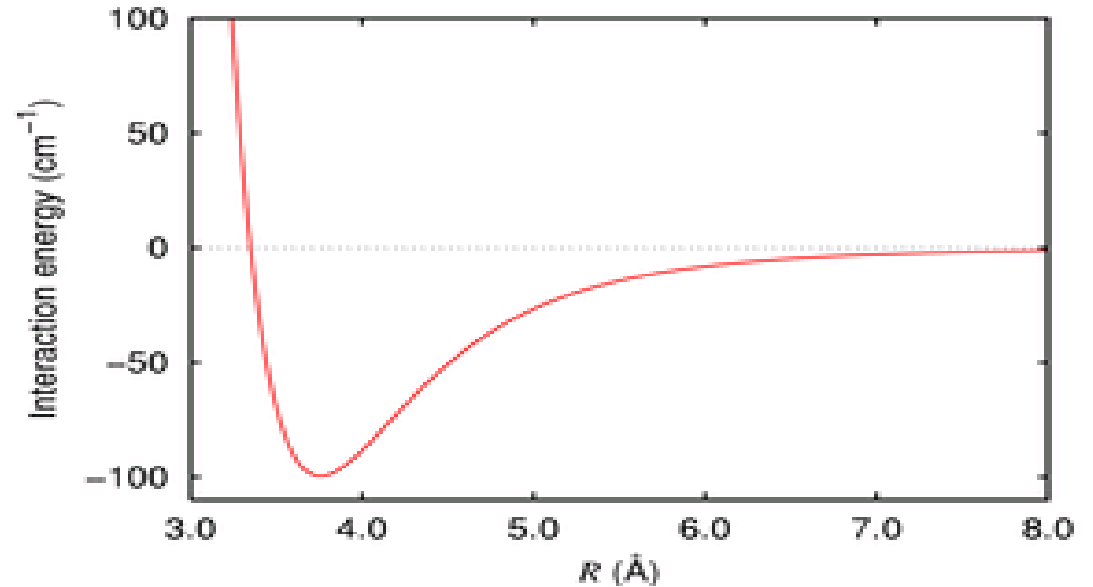
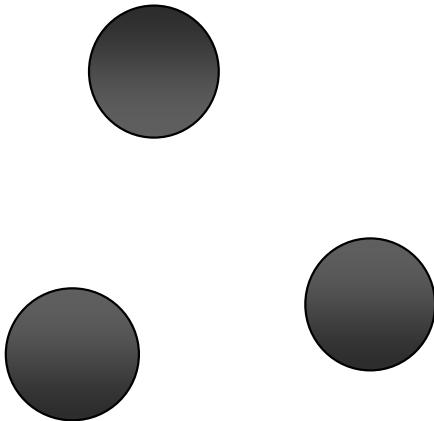
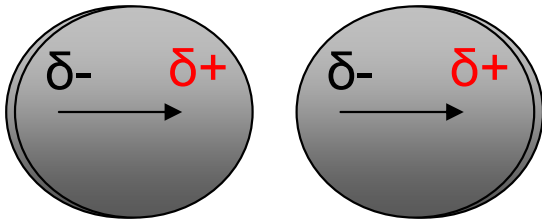

$$V = \frac{-Aa}{12H}$$

A: Effective Hamaker constant

a: Radius of the particles

H: Distance between particles

Steric Stabilization

- Steric stabilization¹:

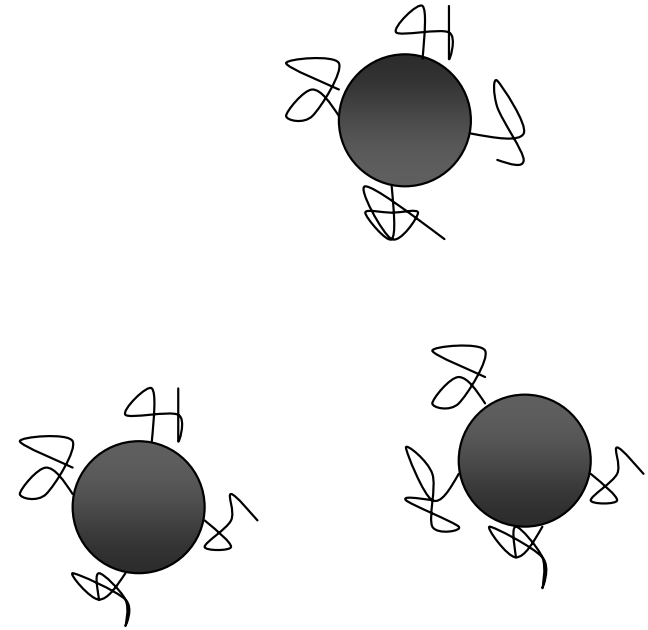

- Independent of electrolyte concentration
- Applicable to polar and non-polar solvents
- Reversible flocculation (non solvent/good solvent)

1. Napper (1983). "Polymeric Stabilization of Colloidal Dispersions", p. 20. Academic Press, London.

Stabilizers

- Small molecule surfactants: CTAB, SDS, etc.
 - Polymers: Homopolymers, telechelic polymers, block copolymers
- Advantages of polymers:
 - Increased colloidal stability
 - Protection from oxidation
 - “Polymeric field” (hydrophobic, electrostatic, acidic, etc.)

Outline

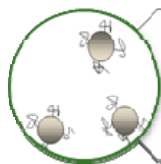

Background



Hydrogenation Reactions

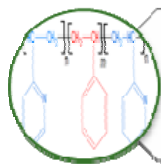

Polymers Synthesis

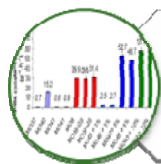

Results

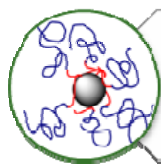

Conclusions

Nickel Nanoparticles

- Supplied by Vale-Inco
- Synthesized by gas condensation technique

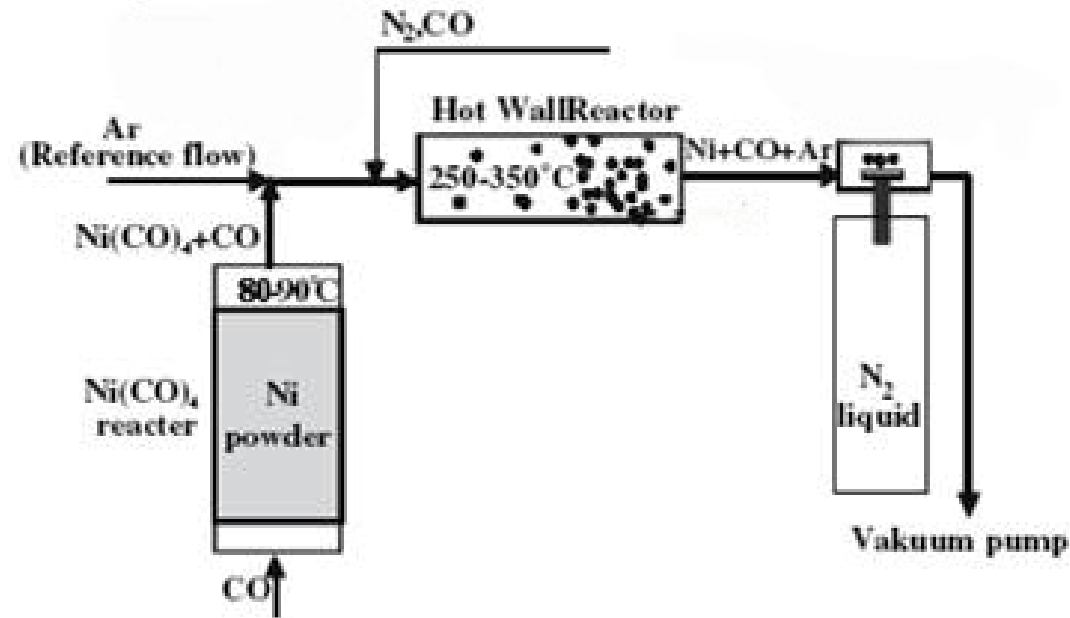

- Control over size, composition (residual C,O)



Inco Nanoparticles – Size Distribution

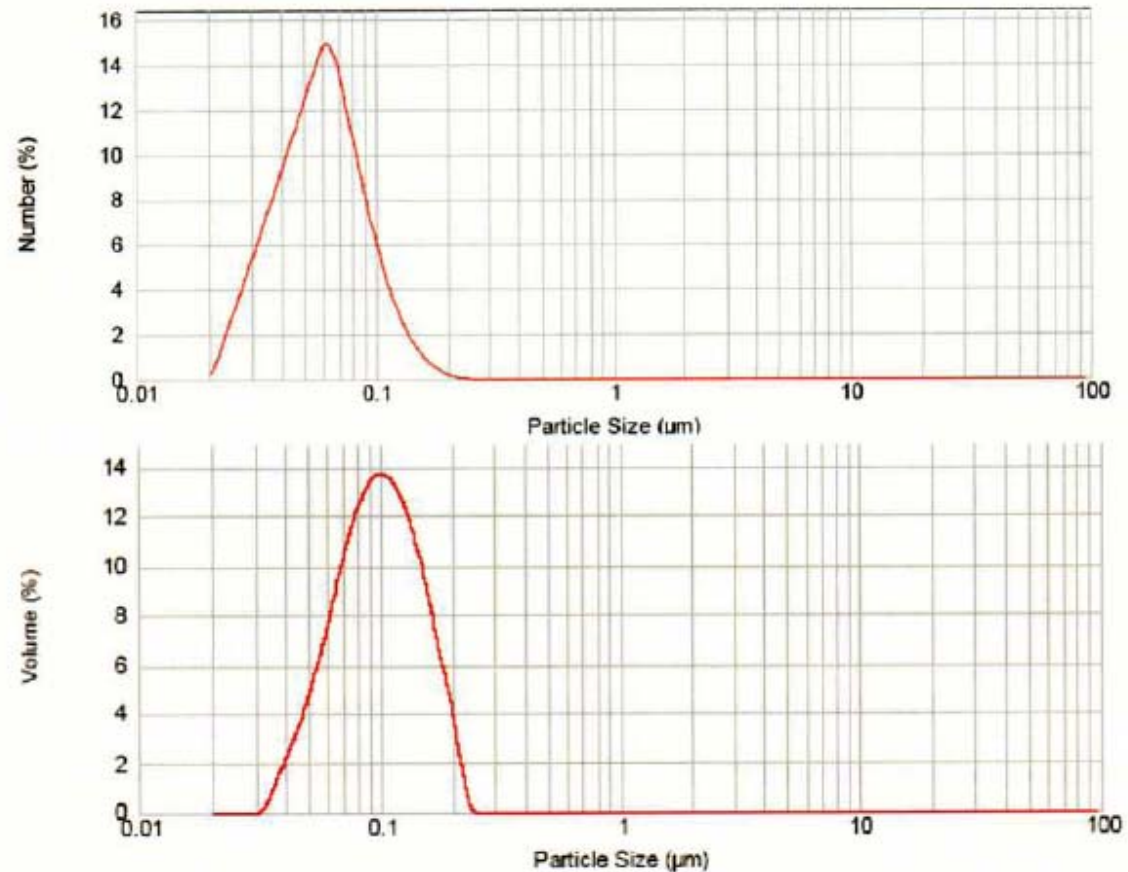
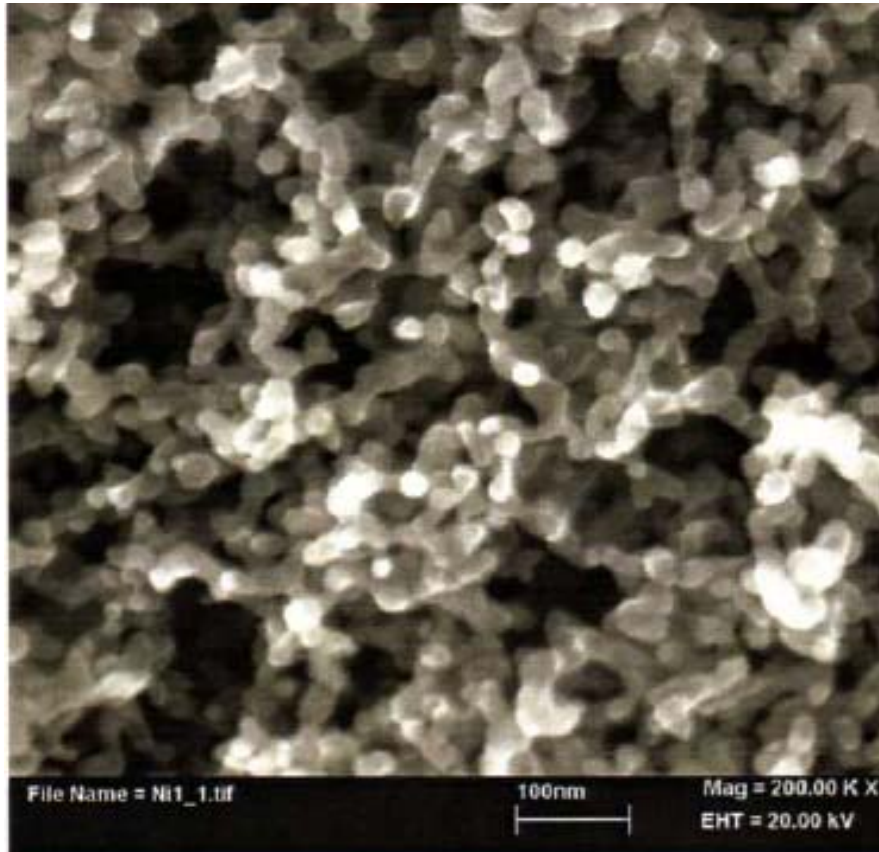

Average particle size: 60 nm

Broad size distribution

Hydrogenation Reactions

- Adiponitrile:
Precursor in nylon-6,6 synthesis

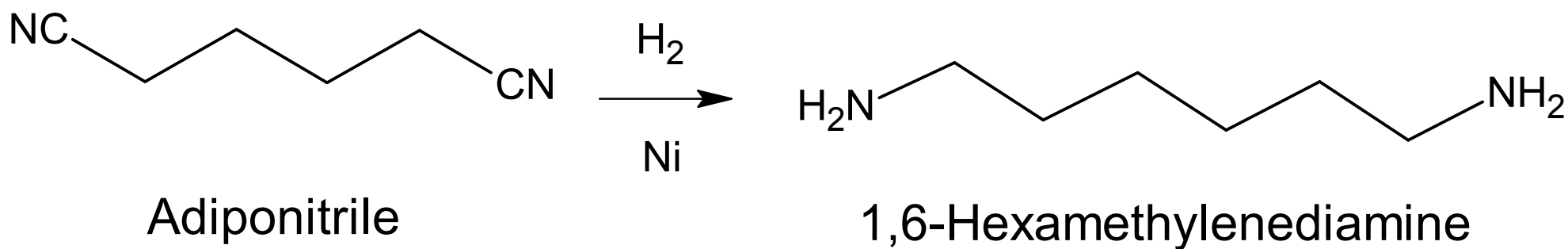

Hydrogenation Reactions (cont'd)

- Mesityl oxide:
Precursor for methyl isobutyl ketone (solvent)

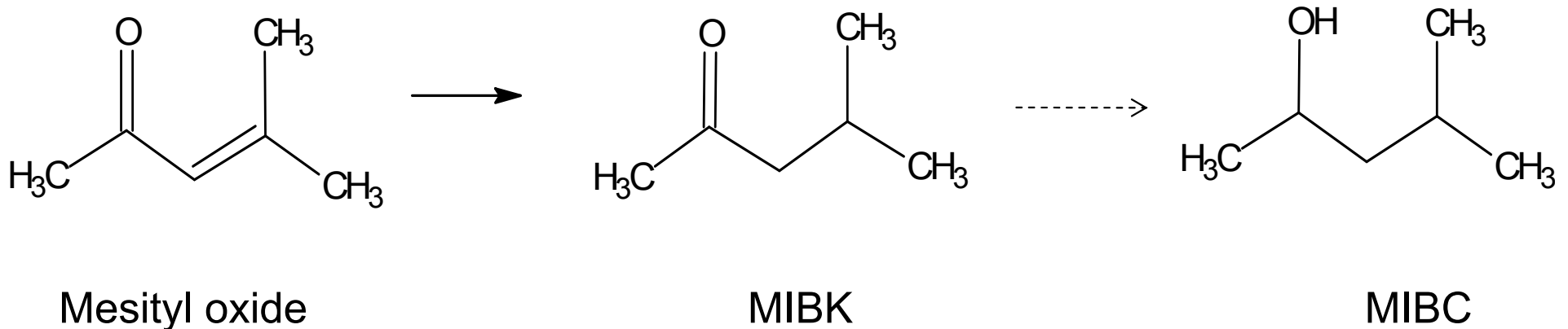

Hydrogenation Reactions (cont'd)

- Nickel particles (under N₂)
- Addition of substrate (mesityl oxide) and particles to solvent (2-propanol)
- Sonication
- Reaction:
 - 200 psig, 50°C, 330 rpm
 - Conversion monitoring



Outline

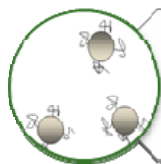

Background



Hydrogenation Reactions

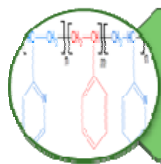

Polymers Synthesis

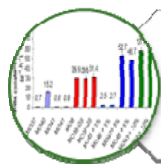

Results

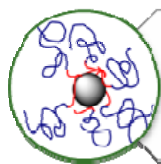

Conclusions

Polymeric Stabilizers

- Telechelic polymers:

- PEO-diethylenetriamine
- PEO-bis-2-picolyamine
- PEO-COOH

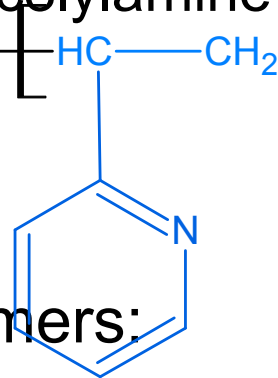

- Diblock copolymers:

- PS-*block*-PMMA
- PS-*block*-P2VP

- Triblock copolymers:

- PEO-*block*-PS-*block*-PEO
- P2VP-*block*-PS-*block*-P2VP

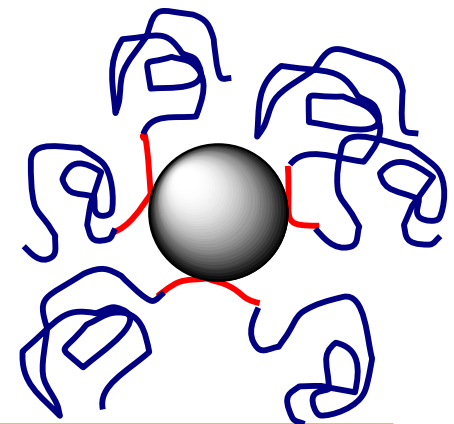
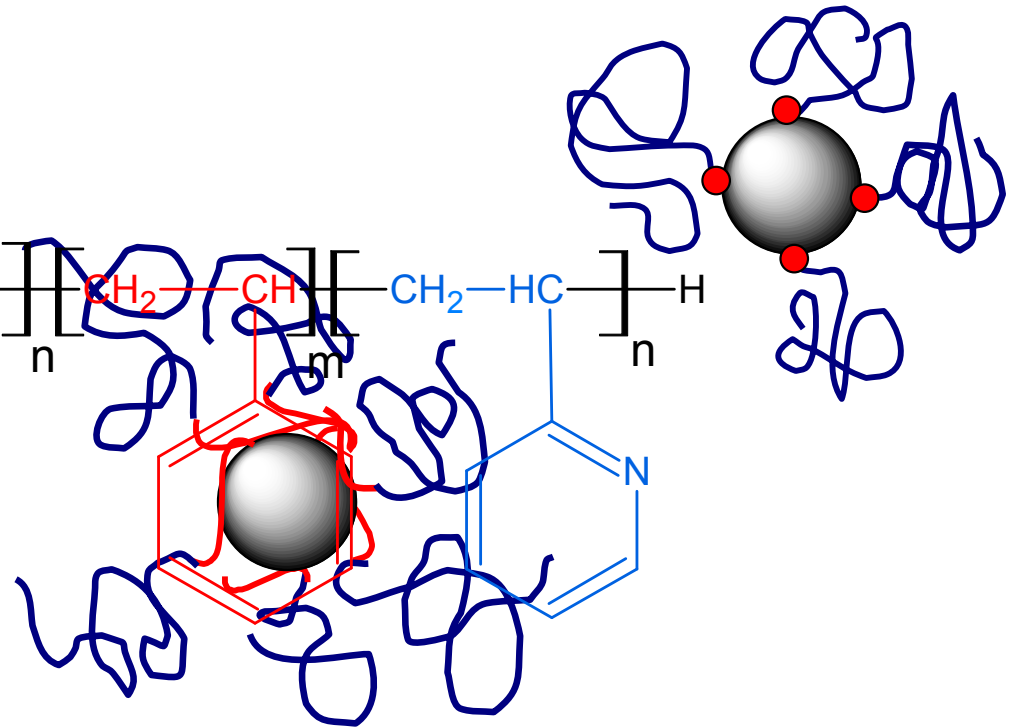

Synthesis: Triblock Copolymer

Electron-transfer Initiator:

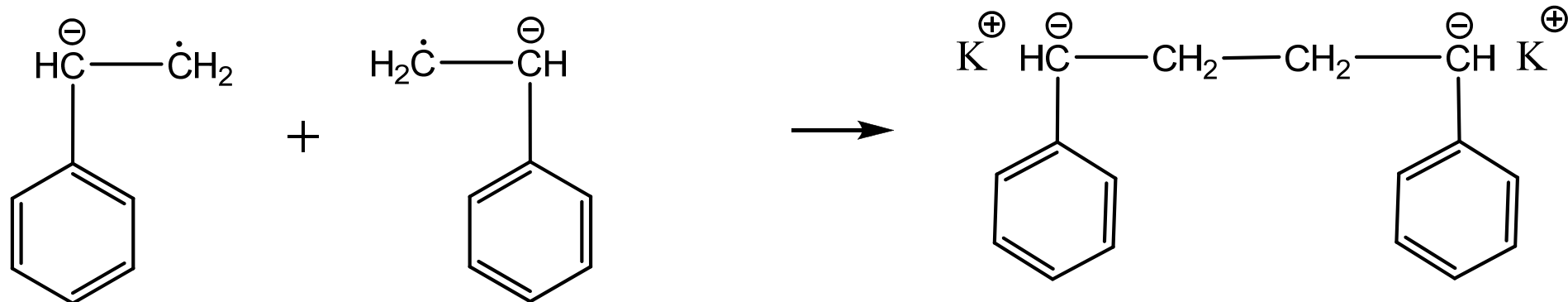
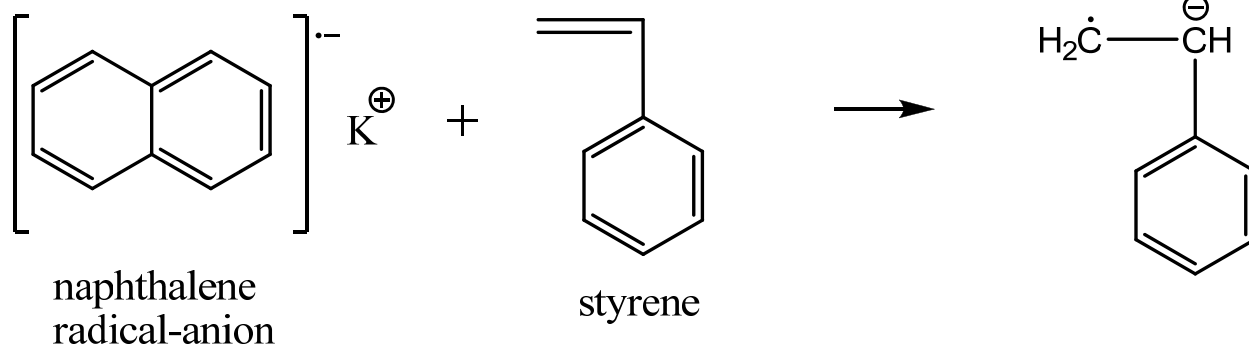

Synthesis: Triblock Copolymer (cont'd)

PS addition:

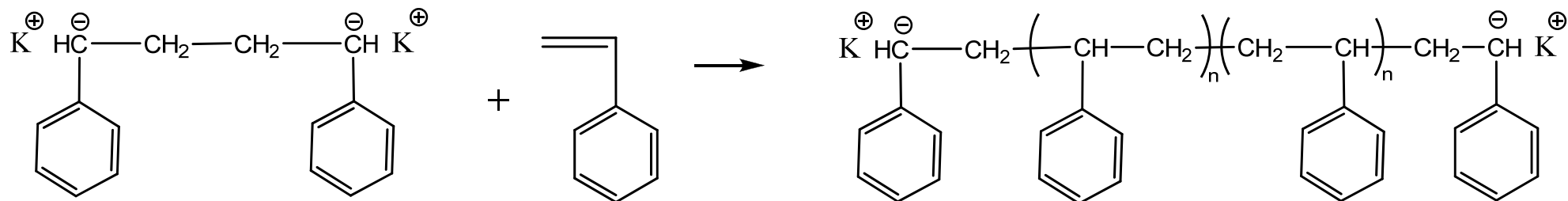

P2VP addition:

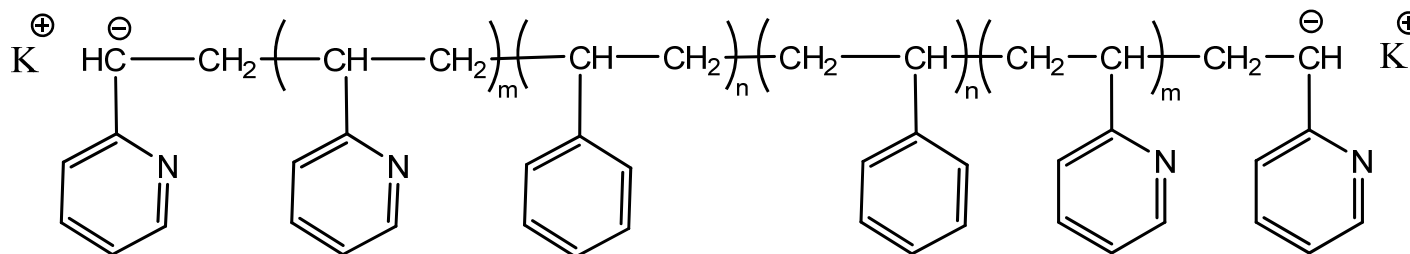
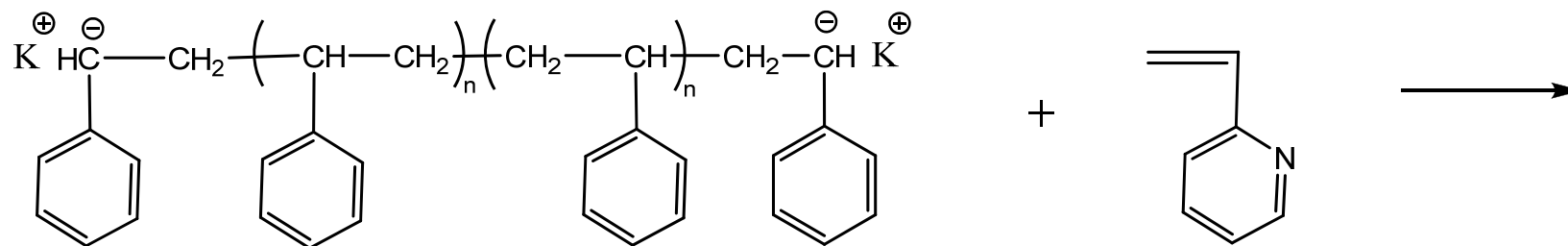

Termination: HCl/MeOH

Outline

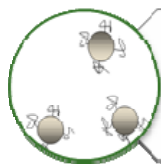

Background



Hydrogenation Reactions

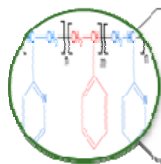

Polymers Synthesis

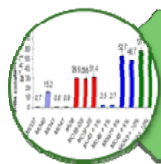

Results

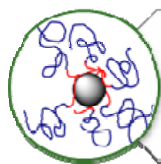

Conclusions

Nanoparticles Activity: Adiponitrile

- Nanoparticles more than 3X more active than Raney nickel
- Important variations among nanonickel samples

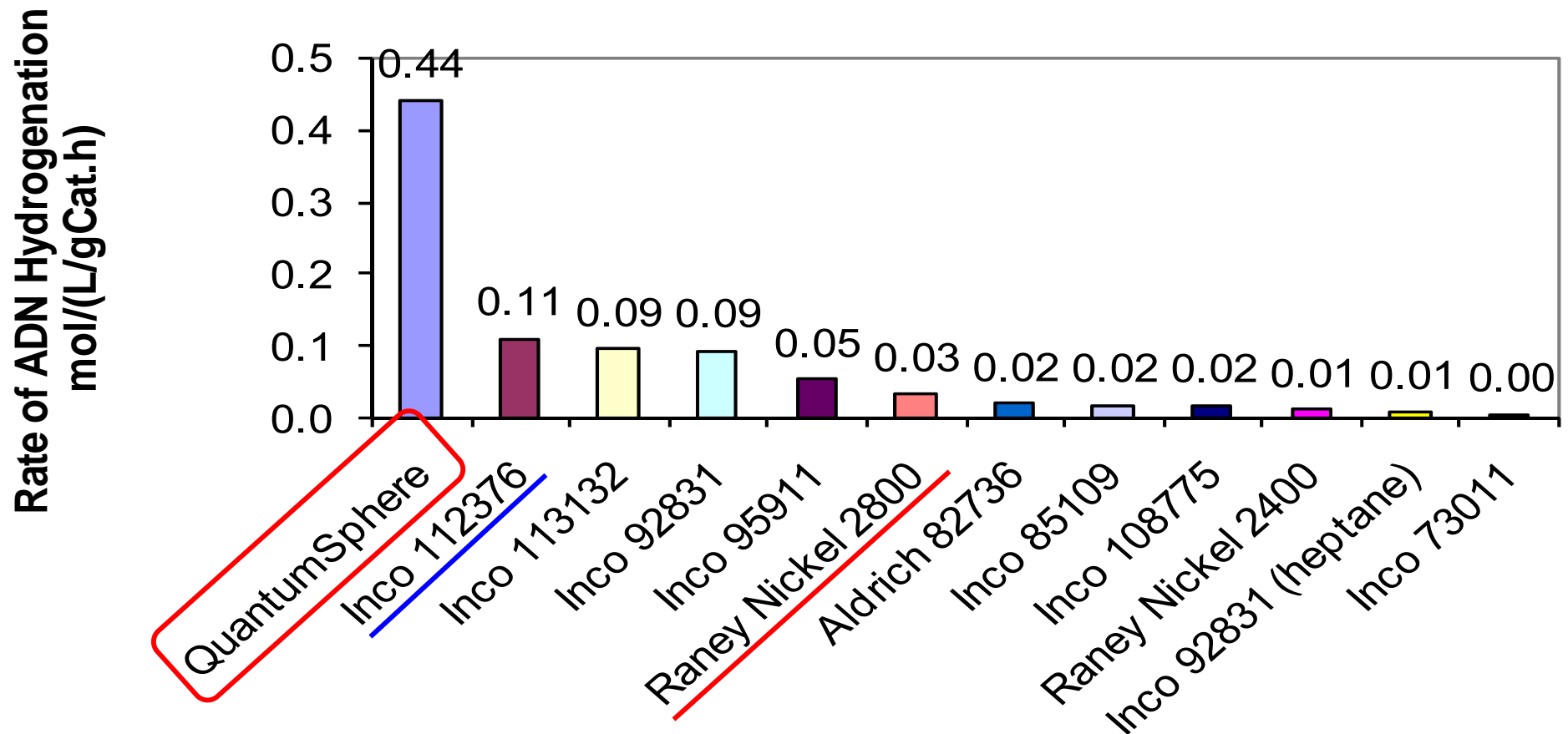

Nanoparticles Activity: Mesityl Oxide

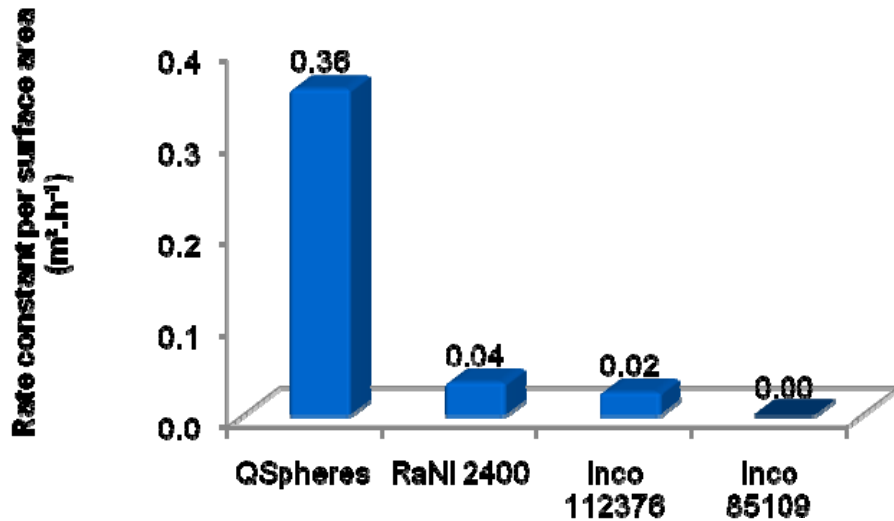

→ Increased activity
Solubilization of nickel
oxide surface

Diethylenetriamine (DETA)
treatment

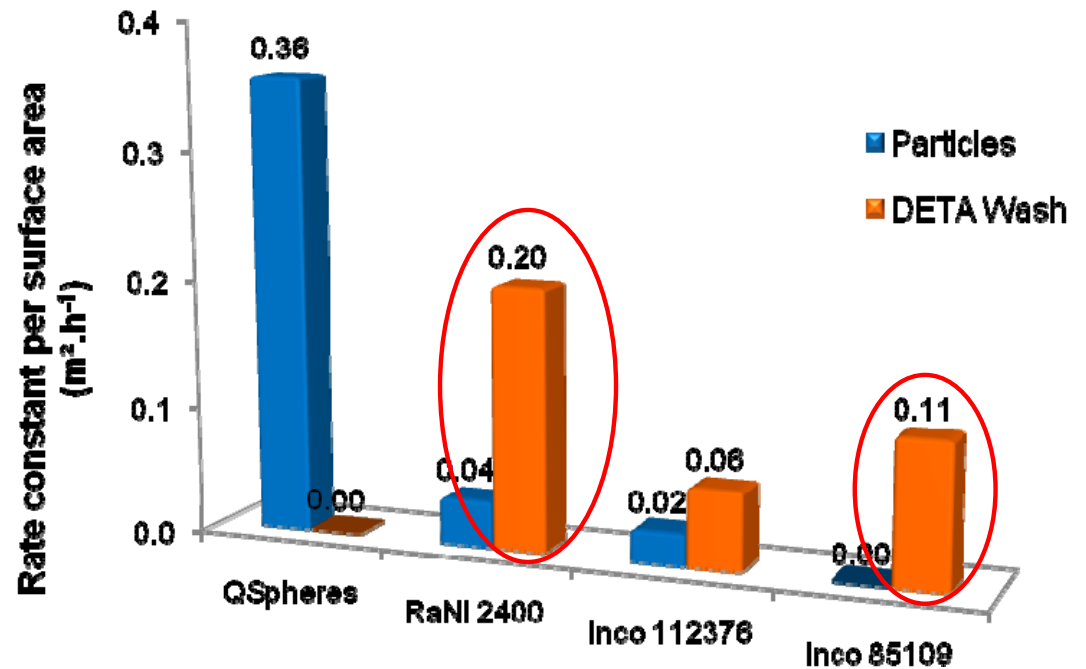

Inco 982174 – 97 m²/g

- Activity variation for bare nanoparticles

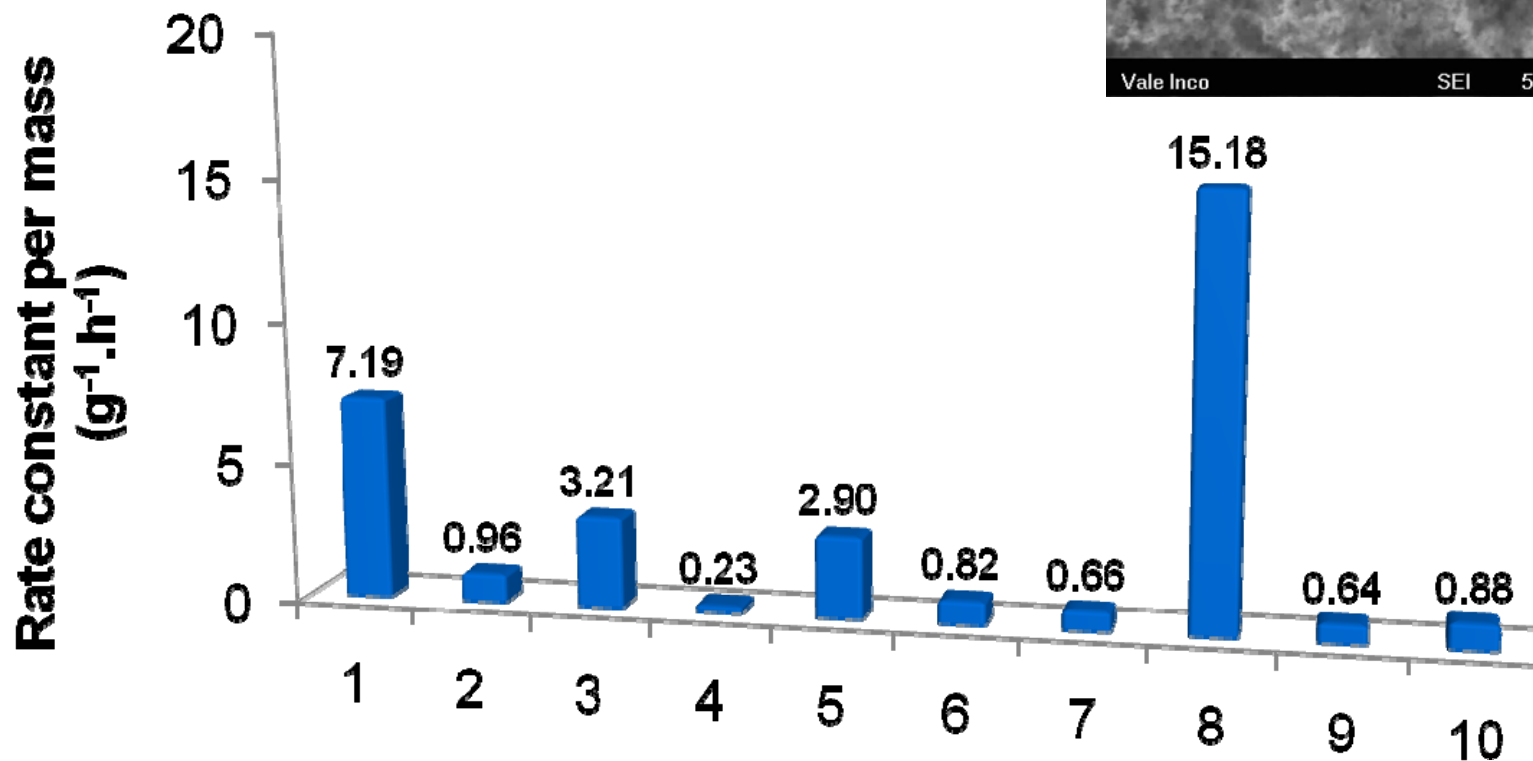
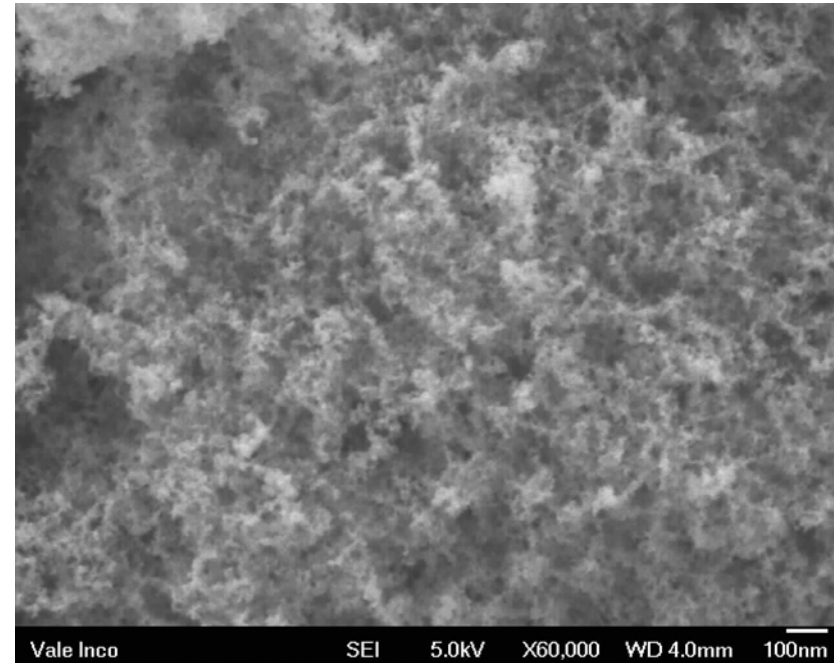

Inco 982174 (cont'd)

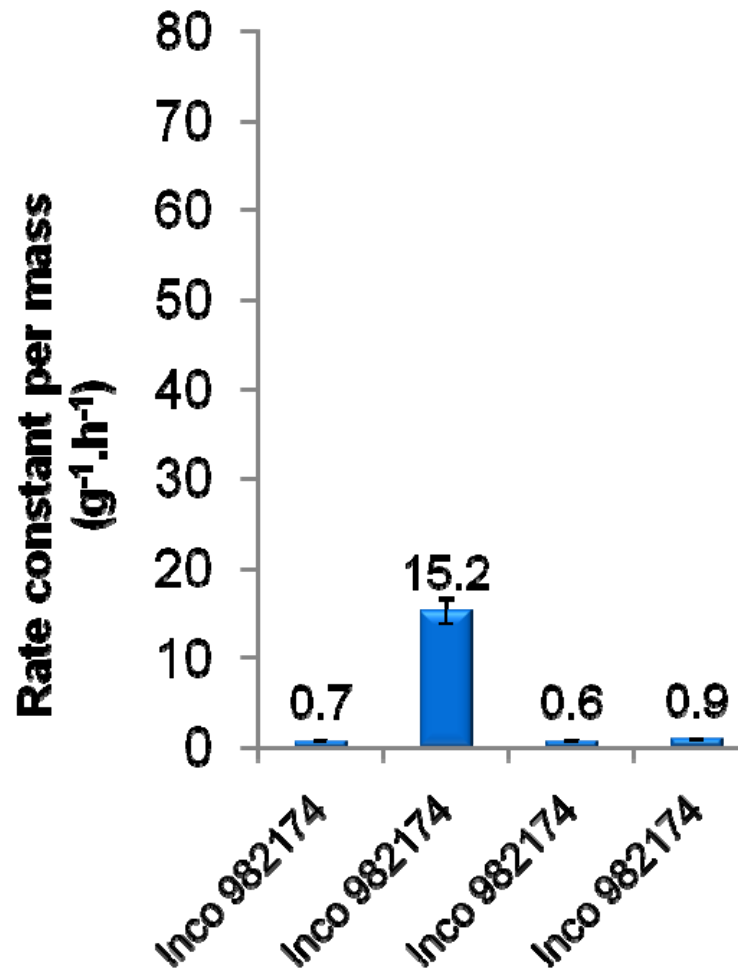

Outline

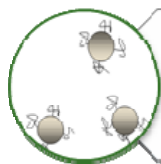

Background



Hydrogenation Reactions

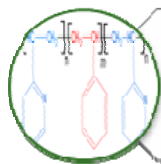

Polymers Synthesis

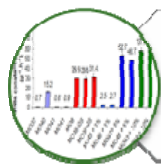

Results

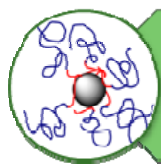

Conclusions

Conclusions

- Different stabilizing polymers synthesized
- Triblock copolymers work best
- Protective effect from oxidation
- Catalytic activity and colloidal stability of nanoparticles enhanced

Applications

- Mixed catalyst systems (Ni+Fe, Co)
- Applications as efficient catalytic systems (fuel cells, specialty chemicals synthesis, etc.)
- Tailoring of polymer structure and composition

Acknowledgements

- Supervisor: Prof. Mario Gauthier
- Co-supervisor: Prof. Flora T.T. Ng
- Vale - Inco:
 - Vladimir Paserin
 - Steve Baksa
 - Jun Shu
 - Nam Nguyen
- Colleagues in the Gauthier and Duhamel Labs

Thank You

Any questions



Size Effect

- Size decreases:
 - High surface-to-volume ratio
 - Quantum effects

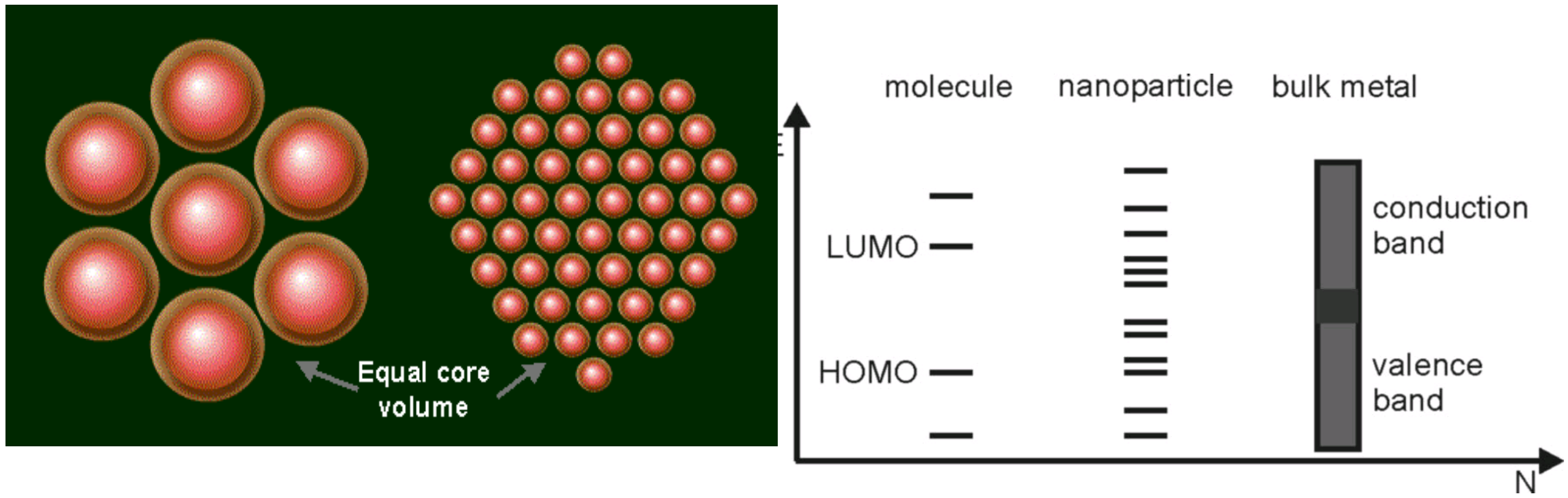

D.B. van Wyck, Anna CE Symposium, New Orleans, LA, 2004.

Size Dependence

- Increased activity with decreasing size
- Maximum in activity can be observed

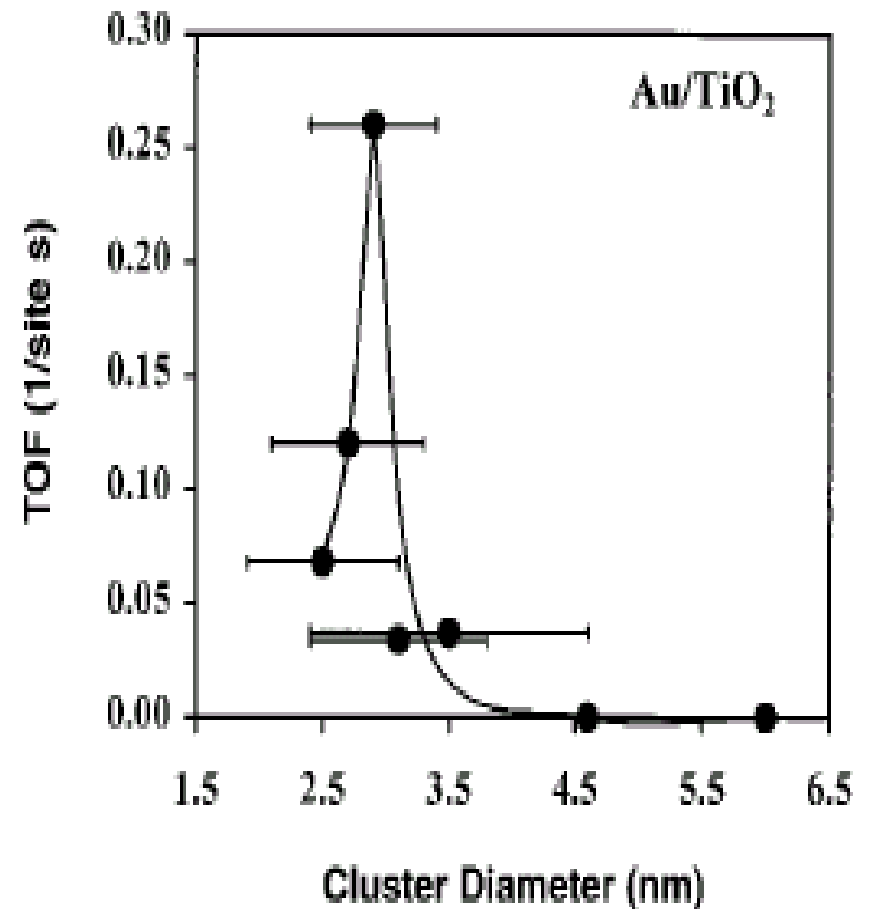

London Interaction Energy

- Hamaker constant for 60 nm particles:
 - Ni = 22.10^{-20} J
 - Ethanol = $4.20 \cdot 10^{-20}$ J

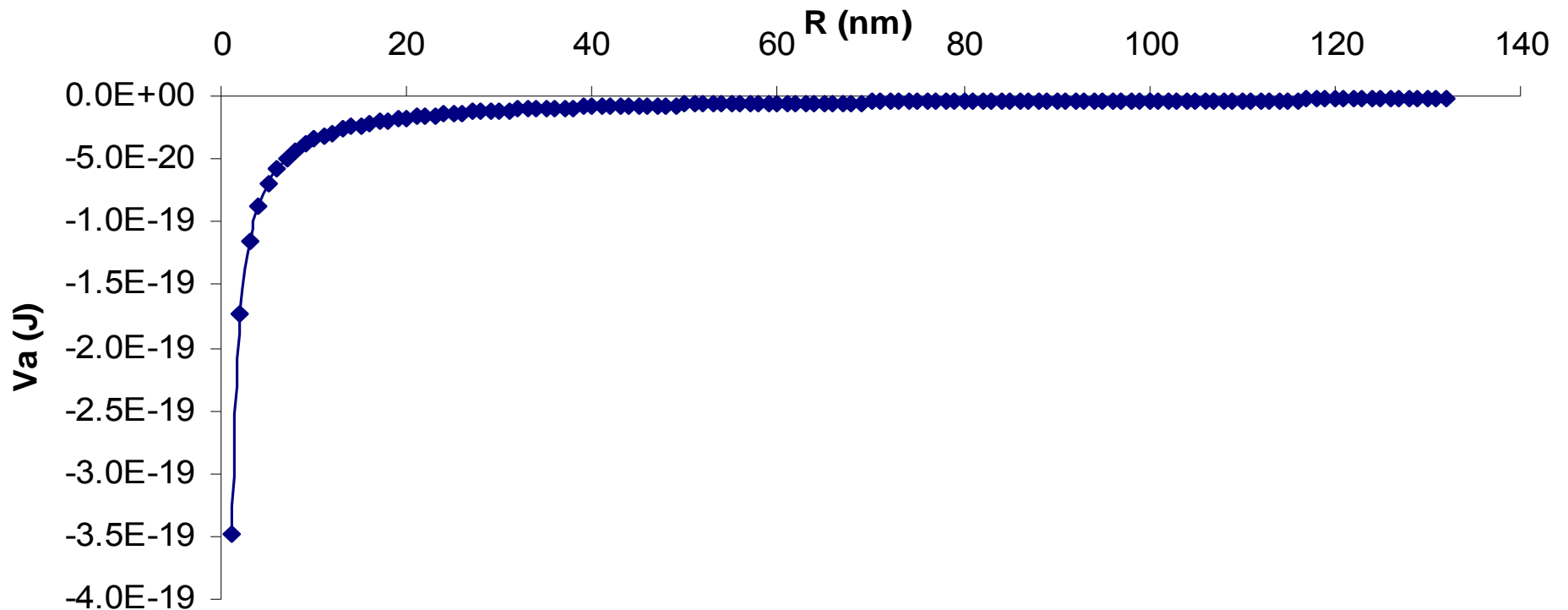

Rate Constant Determination

■ Kinetics:

- Sampling
- GC analysis

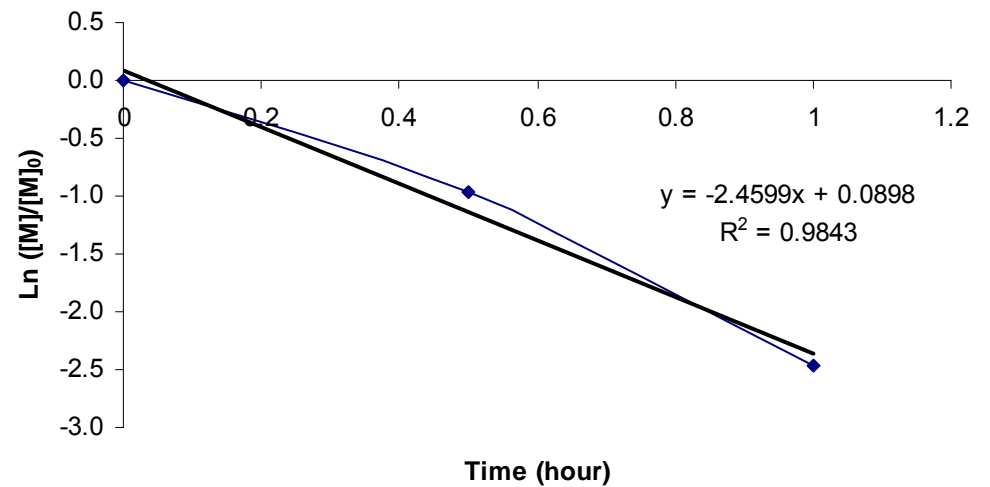
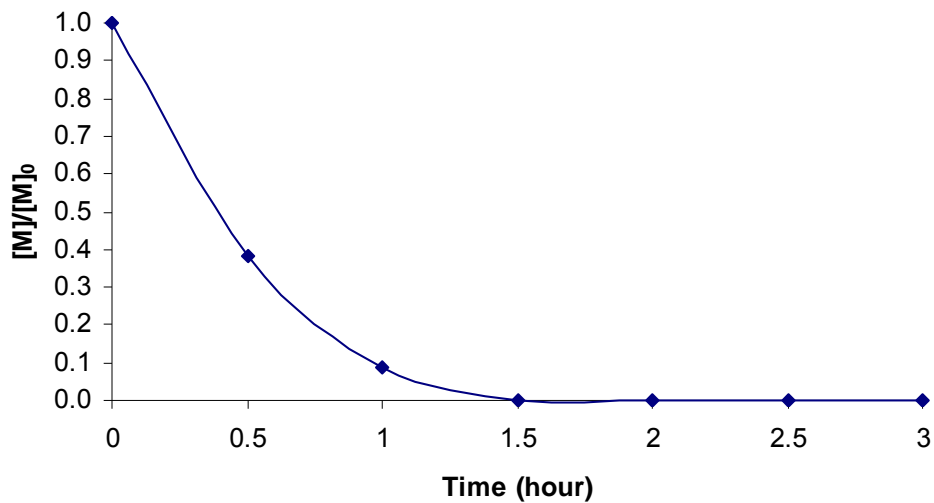

Inco 982174 + 5% polymer

Nanoparticles Activity: Adiponitrile (cont'd)

- Rate of hydrogenation normalized per surface area

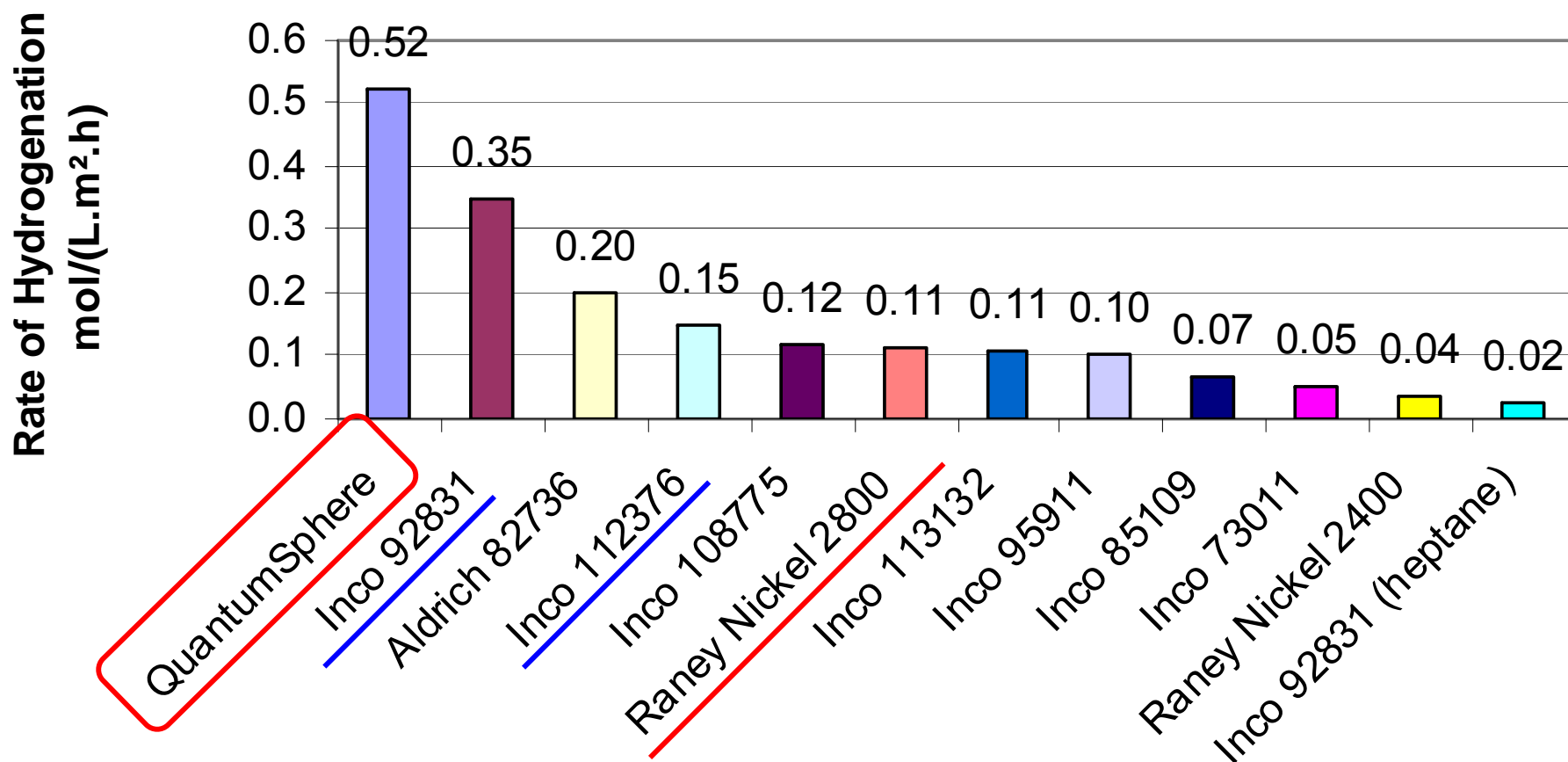

Colloidal Stability in Water

Inco 82325 (23 mg) in Water (10 mL) with Stabilizer

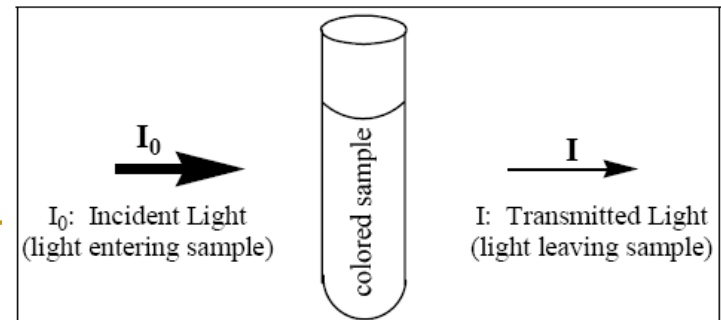
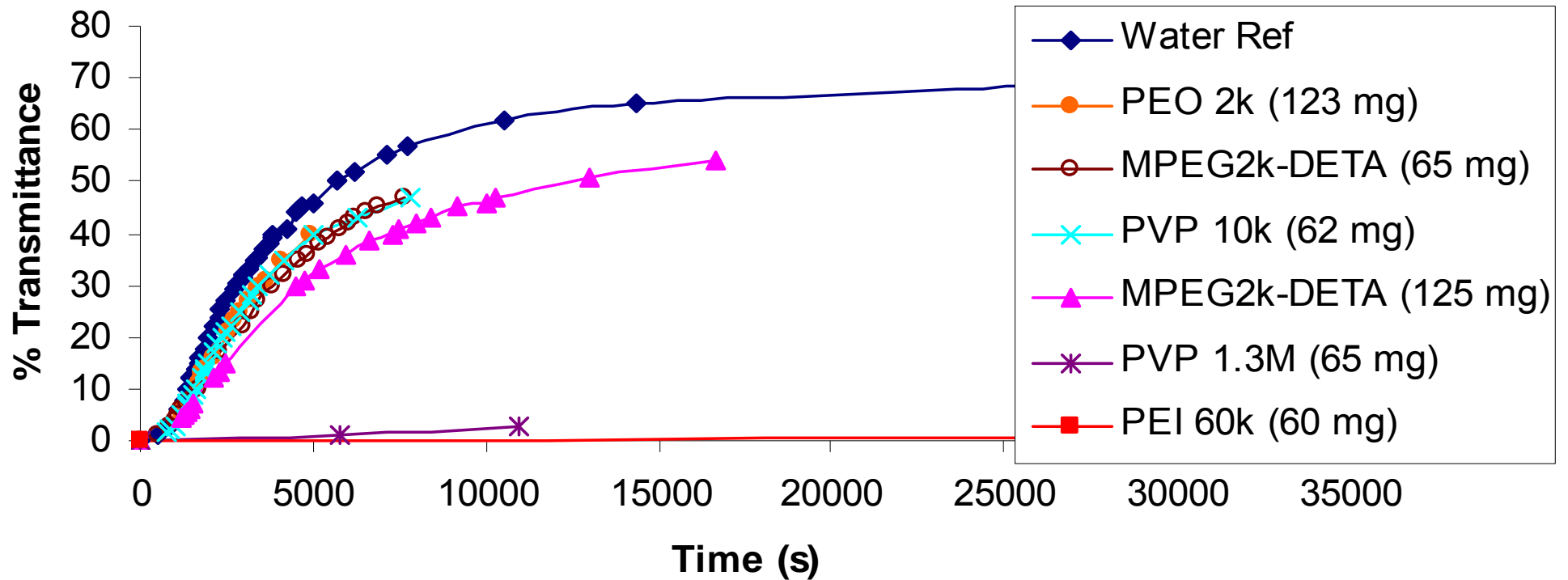

Polymer Bridging Effect

- Interactions of stabilizing polymer with two different particles
- Significant at low polymer concentration
 - May induce catalyst flocculation

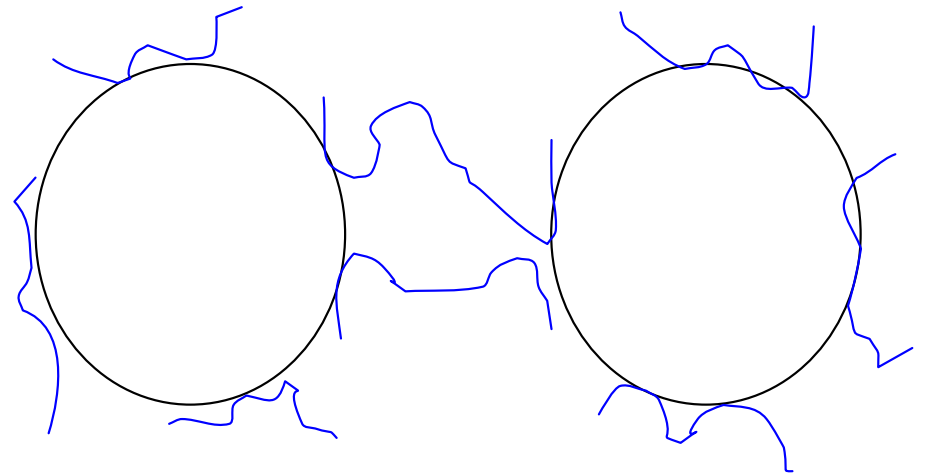

Inco 85109 in Methanol

t = 0 min
t = 1 min
t = 30 min
t = 1 h
t = 2 h
t = 2 h 30
t = 4 h



Polymer/ Particles (mg/mg)	0	10	1	0.1	0.003
----------------------------------	---	----	---	-----	-------

Polymer Effects

- “Enormous complexity of the effects [of] polymer chains...”²

D.H. Napper

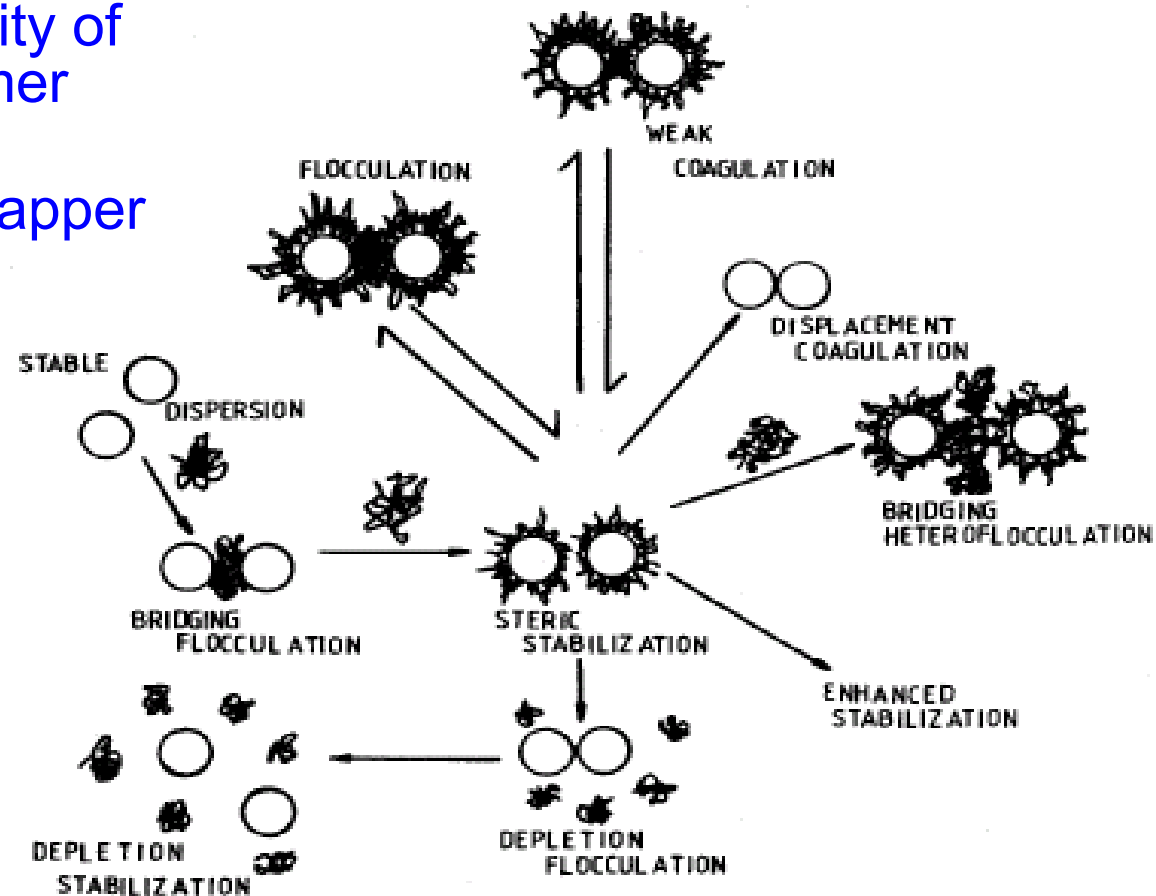

Fig. 17.20. Diagrammatic representation of some of the ways that polymer chains can affect colloid stability.

Effect of Polymer Degree of Polymerization

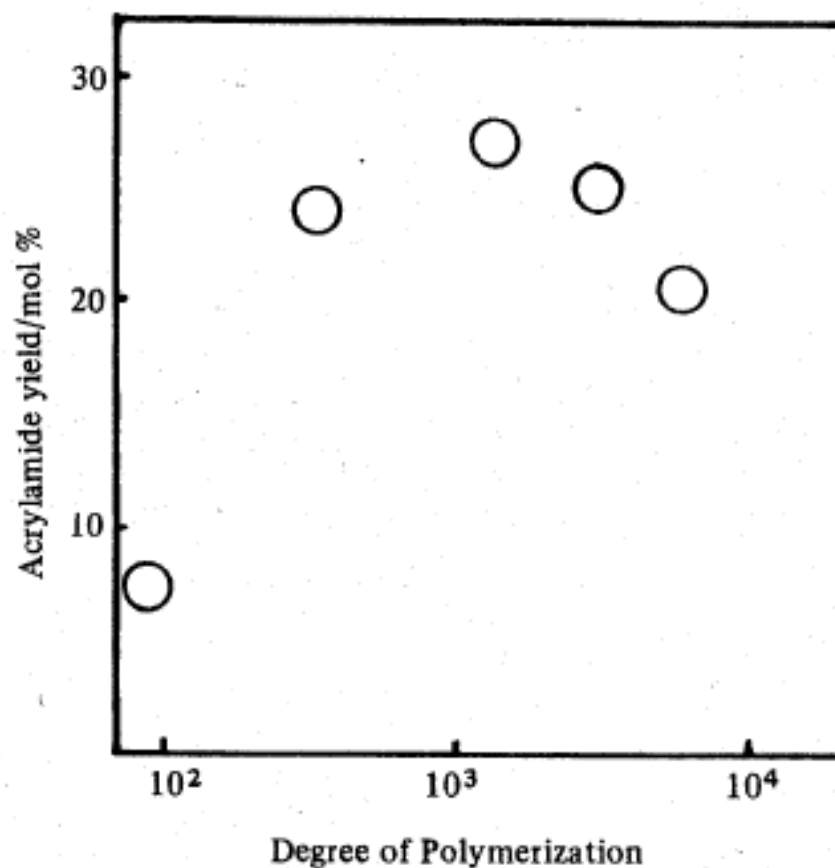

Fig. 21. The influence of the degree of polymerization of poly (vinylpyrrolidone) upon the yield of acrylamide during the hydration of acrylonitrile catalyzed by colloidal copper dispersions protected by poly (vinylpyrrolidone).